

The Intermec logo is displayed in a bold, blue, sans-serif font. It is positioned to the left of a square icon and is partially overlaid by a large, light blue circular graphic element that features several overlapping rings and a central dot, resembling a stylized atom or network diagram.

Intermec



User's Manual



**EasyCoder® 3400e
Bar Code Label
Printer**

Intermec Technologies Corporation

Worldwide Headquarters
6001 36th Ave. W.
Everett, WA 98203
U.S.A.

www.intermec.com

The information contained herein is provided solely for the purpose of allowing customers to operate and service Intermec-manufactured equipment and is not to be released, reproduced, or used for any other purpose without written permission of Intermec Technologies Corporation.

Information and specifications contained in this document are subject to change without prior notice and do not represent a commitment on the part of Intermec Technologies Corporation.

© 2003-2006 Intermec Technologies Corporation. All rights reserved.

The word Intermec, the Intermec logo, Norand, ArciTech, Beverage Routebook, CrossBar, dcBrowser, Duratherm, EasyADC, EasyCoder, EasySet, Fingerprint, INCA (under license), i-gistics, Intellitag, Intellitag Gen2, JANUS, LabelShop, MobileLAN, Picolink, Ready-to-Work, RoutePower, Sabre, ScanPlus, ShopScan, Smart Mobile Computing, TE 2000, Trakker Antares, and Vista Powered are either trademarks or registered trademarks of Intermec Technologies Corporation.

There are U.S. and foreign patents as well as U.S. and foreign patent applications pending.

The name Centronics is wholly owned by GENICOM Corporation.

IBM is a registered trademark of International Business Machines Corporation.

Document Change Record

This page records changes to this document. The document was originally released as version 001.

Version	Date	Description of Change
002	07/2003	Updated the user's manual to include the EasyLAN 10i2 adapter accessory and the EasyLAN Wireless option.
003	09/2006	Updated this manual to include new front matter, a warning about opening the electronics cover, and troubleshooting tip on uneven print quality and ribbon wrinkling.

Contents

Before You Begin.....	ix
Safety Information.....	ix
Global Services and Support.....	ix
Warranty Information.....	ix
Web Support.....	ix
Telephone Support.....	x
Who Should Read This Document?.....	x
Related Documents.....	xi

1 Getting Started..... 1

Getting to Know Your Printer.....	2
Preparing the Printer for Installation.....	3
Plugging In the Printer.....	3
Opening the Printer.....	4
Loading Media for Fanfold Printing.....	5
Printing the Hardware Configuration Test Label.....	7
What the Hardware Configuration Test Label Tells You.....	8
If a Hardware Configuration Test Label Does Not Print.....	8
Connecting the Printer to Your System.....	8
Connecting Your Printer to a PC.....	9
Connecting the Printer to a PC Serial Port.....	9
Connecting the Printer to a PC Parallel Port.....	9
Connecting Your Printer to a Network.....	10
Connecting the Printer to an AS/400.....	10
Connecting the Printer to a Mainframe.....	11
Cabling in Noisy Electrical Environments.....	11
Configuring the Serial Port for Communications.....	12
Verifying Printer Communications With Your System.....	13

2 Operating the Printer..... 15

Learning How to Operate the Printer.....	16
Understanding the Front Panel.....	16
Understanding the Front Panel LEDs.....	16
Using the Feed/Pause Button.....	17
Loading Media Into the Printer.....	18
Loading Roll Media for Straight-Through Printing.....	18
Loading Media for Self-Strip Printing.....	20
Loading Thermal Transfer Ribbon.....	22

Setting the Media Sensitivity Number	24
Setting the MSN for Intermec Media and Ribbon	25
Setting the MSN for Other Media and Ribbon	26
Communicating With the Printer.....	28
Using the PrintSet Software.....	28
Using Third-Party Software.....	28
Using Intermec Printer Language (IPL) Commands	28
Printing a Test Label	29
3 Maintaining the Printer.....	31
Inspecting the Printer	32
Tools for Cleaning the Printer	32
Maintenance Schedule	32
Cleaning the Printhead	34
Cleaning the Printer Covers.....	36
Cleaning the Drive Roller and Tear Bar.....	36
Cleaning the Media Guides and Media Path.....	37
Cleaning the Label Sensors	38
4 Troubleshooting.....	41
Troubleshooting Checklist.....	42
Printer Operation Problems.....	42
Print Quality Problems.....	44
Communication Problems.....	45
Preventing Data Loss	46
5 Optimizing Printer Performance	47
Optimizing and Maintaining Print Quality	48
Correcting Uneven Print Quality.....	48
Adjusting the Print Darkness	49
Adjusting the Label Mark Sensor	50
Using the Printer Memory Efficiently.....	52
How Is the Printer Storage Memory Used?.....	52
Making the Most of Your Memory.....	52
Increasing Throughput	53
What Is an Image Band?.....	53

How the Image Bands Command Works 53
 Optimizing Print Speed and Image Band Setting..... 54

6 Using Test and Service Mode..... 55

Using Test and Service Mode Procedures 56
 Printing Test Labels..... 58
 Using Data Line Print 58
 Resetting the Memory on Your Printer 58

Setting Configuration Commands in Test and Service Mode 59
 Setting the Number of Dot Increments 60
 Adjusting the Label Rest Point..... 61
 Setting Emulation Mode 62
 Using Forms Adjust..... 63
 X Forms Adjust 64
 Y Forms Adjust..... 65

A Specifications..... 67

Printer Specifications 68
 Dimensions (no options installed) 68
 Electrical Requirements 68
 Environment 68
 Character Sets..... 68
 Communications..... 68
 Fonts and Graphics..... 69
 Media 69
 Printhead..... 70
 Printing Method..... 70
 Printing Speed 70
 Ribbon 70
 Self-Strip (optional) 70

Printer Options 71
 Communication Interface..... 71
 EasyLAN 10i Interface..... 71
 EasyLAN 10i2 Adapter..... 71
 EasyLAN Wireless Option..... 71
 Twinax Interface..... 71
 Coax Interface 71
 Finishers 72
 Cutter 72
 Batch Takeup 72
 Self-Strip Printing..... 72
 Kanji/Katakana..... 72
 Memory Expansion 72

Parallel Interface Pin Descriptions 72

Bar Code Symbolologies Supported.....	73
2D Symbolologies	74
2D Stacked Symbolologies	74
2D Matrix Symbolologies.....	75
B Character Sets	77
International Character Sets.....	78
Advanced Character Table.....	78
Emulation Mode Character Table	78
IBM Translation Character Table.....	79
Code Page 850 Character Table.....	80
Extended Character Sets	81
C Communications Reference	85
Communications Protocols	86
Intermec Standard Protocol.....	86
XON/XOFF Protocol (Software and Hardware Flow Control)	87
XON/XOFF, No Status Protocol	88
Polling Mode D.....	88
Multi-Drop Protocol	88
User-Defined Protocol.....	88
Host Requirements.....	90
Communications Boundaries.....	90
Communications Interfaces	90
RS-232 Serial Interface	90
RS-422 Serial Interface	91
RS-485 Serial Interface	91
Printer Serial Port.....	92
D Full ASCII Table	95
Full ASCII Table	96
Full ASCII Control Characters Table	98
G Glossary	99
I Index	107

Before You Begin

This section provides you with safety information, technical support information, and sources for additional product information.

Safety Information

Your safety is extremely important. Read and follow all warnings and cautions in this document before handling and operating Intermec equipment. You can be seriously injured, and equipment and data can be damaged if you do not follow the safety warnings and cautions.



A warning alerts you of an operating procedure, practice, condition, or statement that must be strictly observed to avoid death or serious injury to the persons working on the equipment.



A caution alerts you to an operating procedure, practice, condition, or statement that must be strictly observed to prevent equipment damage or destruction, or corruption or loss of data.



Note: Notes either provide extra information about a topic or contain special instructions for handling a particular condition or set of circumstances.

Global Services and Support

Warranty Information

To understand the warranty for your Intermec product, visit the Intermec web site at www.intermec.com and click **Service & Support > Warranty**.

Disclaimer of warranties: The sample code included in this document is presented for reference only. The code does not necessarily represent complete, tested programs. The code is provided “as is with all faults.” All warranties are expressly disclaimed, including the implied warranties of merchantability and fitness for a particular purpose.

Web Support

Visit the Intermec web site at www.intermec.com to download our current documents (in PDF). To order printed versions of the Intermec manuals, contact your local Intermec representative or distributor.

Visit the Intermec support services knowledge base (Knowledge Central) at intermec.custhelp.com to review technical information or to request technical support for your Intermec product.

Telephone Support

These services are available from Intermecc.

Service	Description	In the U.S.A. and Canada call 1-800-755-5505 and choose this option
Order Intermecc products	<ul style="list-style-type: none">Place an order.Ask about an existing order.	1 and then choose 2
Order Intermecc media	Order printer labels and ribbons.	1 and then choose 1
Order spare parts	Order spare parts.	1 or 2 and then choose 4
Technical Support	Talk to technical support about your Intermecc product.	2 and then choose 2
Service	<ul style="list-style-type: none">Get a return authorization number for authorized service center repair.Request an on-site repair technician.	2 and then choose 1
Service contracts	<ul style="list-style-type: none">Ask about an existing contract.Renew a contract.Inquire about repair billing or other service invoicing questions.	1 or 2 and then choose 3

Outside the U.S.A. and Canada, contact your local Intermecc representative. To search for your local representative, from the Intermecc web site, click **Contact**.

Who Should Read This Document?

Analysts and programmers should use this manual to learn how to operate, program, and connect the printer to a network or system. The first part of this manual tells you how to install, operate, maintain, and troubleshoot your printer. The last part of the manual covers advanced features of the 3400 printers. A basic understanding of programming and data communications is necessary.

Related Documents

The Intermec web site contains Intermec documents (in PDF) that you can download for free.

To download documents

- 1** Visit the Intermec web site at www.intermec.com.
- 2** Click **Service & Support > Manuals**.
- 3** In the **Select a Product** field, choose the product whose documentation you want to download.

To order printed versions of the Intermec manuals, contact your local Intermec representative or distributor.

Before You Begin



1 Getting Started

This chapter describes the EasyCoder® 3400e printer and explains how to get your new printer running for the first time. This chapter covers these topics:

- Learning about the printer
- Preparing the printer for installation
- Connecting the printer to your system
- Configuring the printer's serial port
- Verifying printer communications with your system

Getting to Know Your Printer

Features of your printer include:

- support for direct thermal and thermal transfer printing applications. Chapters 1 and 2 explain how to load both types of media.
- an internal optional self-strip with integral liner takeup. See Chapter 2, “Operating the Printer,” for more information.
- an easy-to-use software application called PrintSet. PrintSet makes configuring your printer, downloading fonts and graphics, and printing a test label effortless.
- minimal supervision and maintenance.
- support for user-supplied fonts. You can easily download and print user-supplied fonts. See the PrintSet software application or the *IPL Programming Reference Manual* (P/N 066396) for more information.
- support for TrueType. You can easily download and print TrueType fonts. See the PrintSet software application or the *IPL Programming Reference Manual* for more information.
- e series—IEEE 1284 parallel port. Up to 8 ips (inches per second) print speed with selected media.

Use the following illustrations to familiarize yourself with your printer.

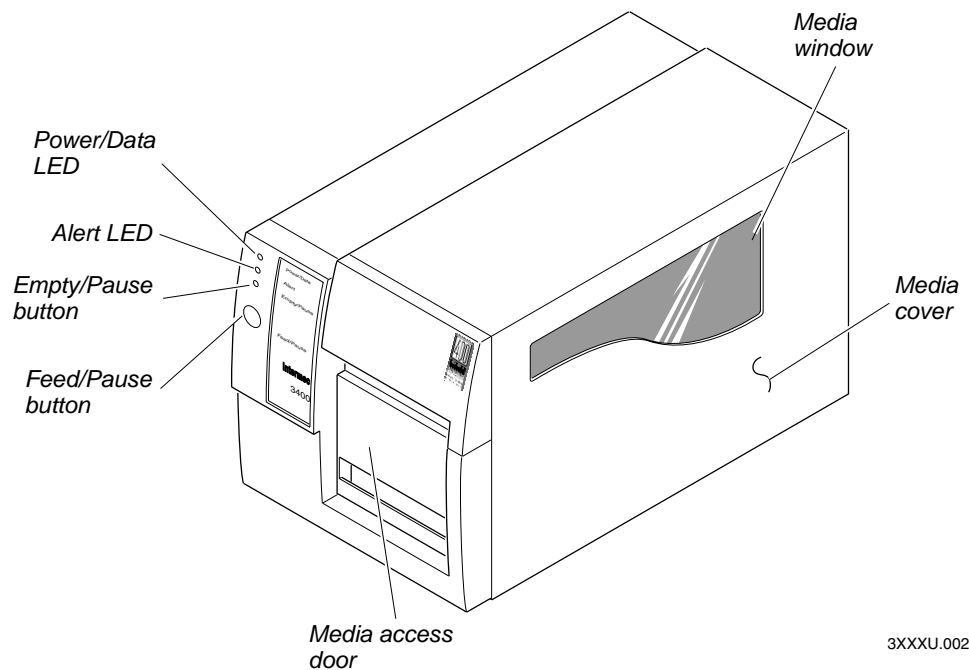

3400e front view: This illustration shows the features on the front of the 3400e.

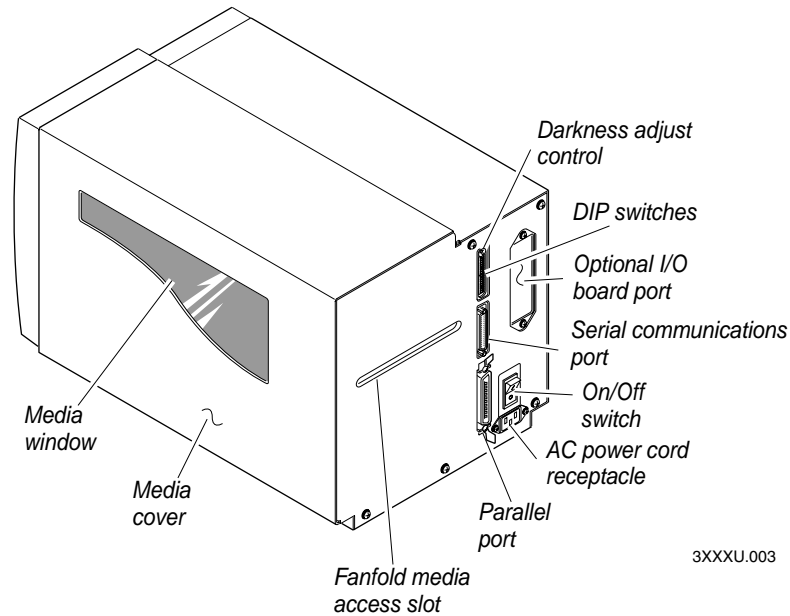

3400e back view: This illustration shows the features on the back of the 3400e.

Several options are available for use with your printer. See Appendix A, “Specifications,” for complete descriptions of these options.

Preparing the Printer for Installation

Before connecting your printer to your data collection system, you need to:

- plug in the printer.
- open the printer and load media.
- print a configuration test label.

Plugging In the Printer

The back of your printer contains the AC power receptacle, the serial communications port, the On/Off switch, and two banks of DIP switches.

To plug in the printer

- 1 Turn the On/Off switch to the off position.
- 2 Make sure you set the DIP switches to their factory default settings.

Top Bank Set switch 1 on (I). Set switches 2 through 8 off (O).

Bottom Bank Set switches 1 through 8 off (O).

For a description of the DIP switch settings, see “Configuring the Serial Port for Communications” on page 12.

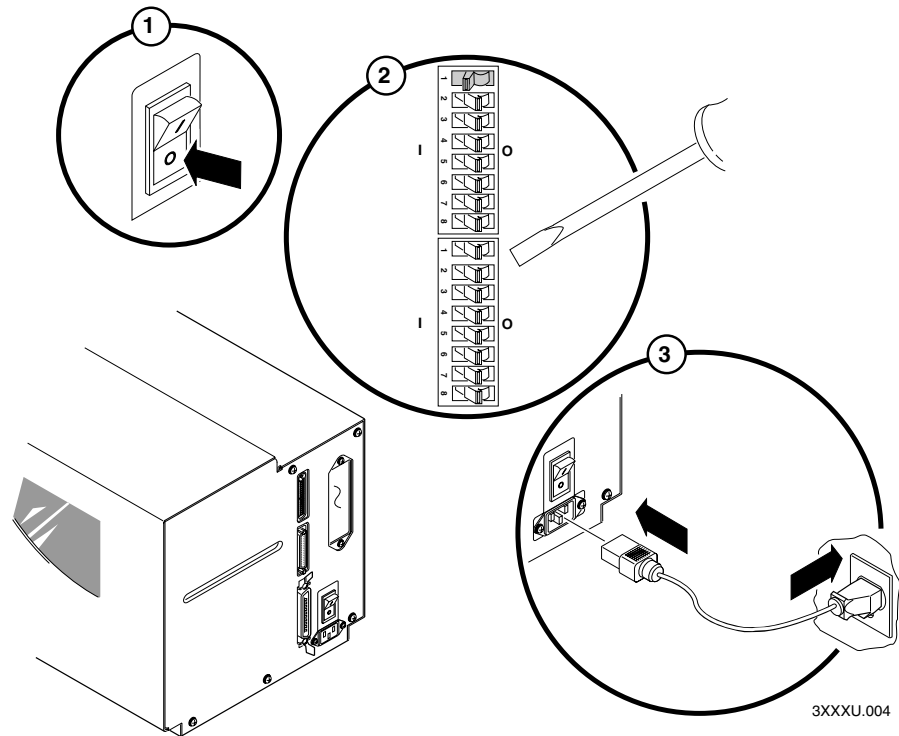

3XX XU.004

- 3 Plug the AC power cord into the receptacle at the rear of the printer. Plug the other end of the power cord into a grounded wall outlet or surge protector.
- 4 Turn the On/Off switch to the on position. When you power on the printer, the Power On LED lights, the Empty/Pause LED flashes, and the platen roller advances. The yellow Empty/Pause LED then stays on steady because you have not loaded media yet.

Opening the Printer

You need to open the printer every time you load media or perform maintenance procedures.

To open the printer

- 1 Place the fingers of your right hand between the two notches on the lower edge of the media cover (the media cover release) and pull the bottom of the media cover away from the base of the printer. See the next illustration.

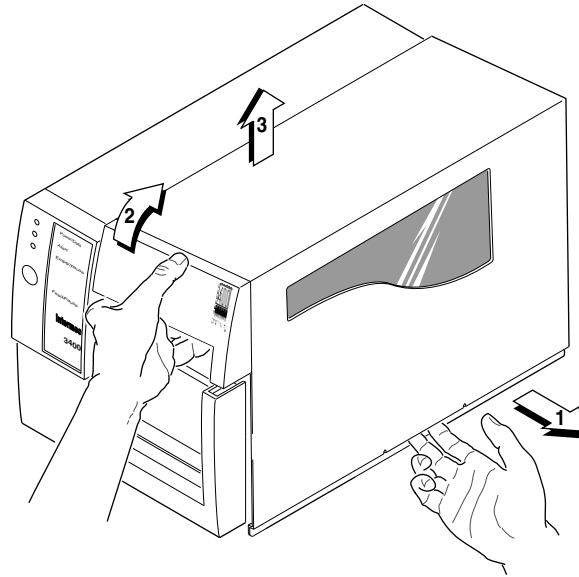

3XXU.005

- 2 Grasp the front of the media cover with your left hand and lift the front of the media cover upward to release it from the printer frame.
- 3 Lift the media cover away from the top of the printer.

Loading Media for Fanfold Printing

Use the sample of fanfold media provided in the Media Envelope to complete the following procedures. In fanfold printing, you place a stack of fanfold media at the rear of the printer and feed it into the printer through a slot in the rear cover. Refer to Chapter 2, “Operating the Printer,” for instructions on loading rolls of media.

To load media for fanfold printing

- 1 Open the printer.
- 2 Disengage the printhead by rotating the head lift lever clockwise until it releases.
- 3 Move the supply roll retainer by turning it counterclockwise and sliding it to the outer end of the supply roll post.
- 4 Place the fanfold media slightly lower than the slot in the printer back cover. Line the (box of) fanfold media up with the label path through the printer. Insert media through the slot at the rear of the printer and thread it over the supply roll post. See the next illustration.

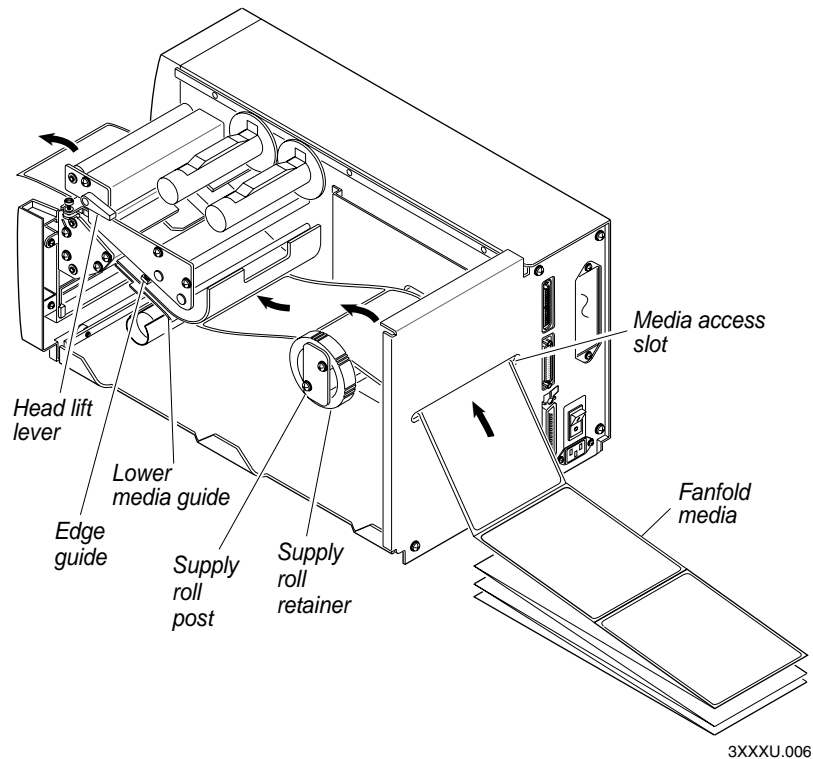

- 5 To allow easy access to the media path, pull down on the lower media guide. Make sure that the edge guide is slid all the way to the outer edge of the edge guide plate.
- 6 Insert the fanfold media through the printer mechanism as shown in the next illustration. The front edge of the media should pass over the tear bar and through the label dispense opening in the media cover. The fanfold media should pass over the supply roll post.
- 7 Release the lower media guide and adjust the edge guide to position the media firmly against the inside wall of the printer.
- 8 Slide the supply roll retainer up to the edge of the fanfold media and turn the supply roll retainer clockwise until it locks firmly in place securing the media against the inside wall of the printer.
- 9 Engage the printhead by rotating the head lift lever counterclockwise until it locks.
- 10 Close the printer by reversing the directions for removing the cover.
- 11 Press Feed/Pause to advance one label through the printer and out the label opening in the front cover. The printer is now ready to print the configuration test label. The yellow Empty/Pause LED goes out.

If the yellow Empty/Pause LED does not go out, press Feed/Pause a second time and then reload the media and try again if the Empty/Pause LED still does not go out.



Note: For your convenience, refer to the label with directions for loading media. This label is located on the inside of the media cover.

Printing the Hardware Configuration Test Label

You can print the hardware configuration test label to test the printer and make sure it is operating correctly. The hardware configuration test label lists the printer's configuration. Use this label for reference when installing your printer and for verification of proper printer operation.

To print the hardware configuration test label

- 1 Turn the On/Off switch to the off position.
- 2 Press and hold the Feed/Pause button while you turn the On/Off switch to the on position. The Alert and Empty/Pause LEDs blink during the printer self-test.
- 3 Release the Feed/Pause button when the media starts moving. The printer feeds out one or two blank labels and then prints the hardware configuration test label.



Note: This is only an example of a hardware configuration label. Your label may not be exactly the same.

3400e Hardware Configuration	
Memory Installed	
Flash Storage	: 128 kilobytes
Image RAM	: 805 kilobytes
Flash SIMM	: OKB
Mileage	
Inches Processed	: 0
Inches Burned	: 0
Labels Cut	: 0
Printhead	
Width	: 1792
Dot Size	: 2.5
Burn Pot Setting	: 141
Hardware Options	
I/O Option	: none
Internal Option	: none
External Option	: Cutter
Firmware Checksum	
ROM0 (U21)	: 95D0
ROM1 (U9)	: 7331
Program	: 067097
Version	: 2.0

3XXXU.007

- 4 Turn the printer power off and then on. You are now ready to connect your 3400e printer to your system.

What the Hardware Configuration Test Label Tells You

The hardware test label provides these statistics:

- Amount of installed memory
- Amount of media printed
- Printhead configuration
- Firmware information
- Printhead alignment (the vertical lines)

If a Hardware Configuration Test Label Does Not Print

If you are unable to print a hardware configuration test label, see “Printer Operation Problems” on page 42.

Connecting the Printer to Your System

You can connect your printer to a PC, a local area network, an AS/400 (or other midrange computer), or a mainframe. This section tells you how to connect your printer to any of these systems.

You can use any of these three ports on the rear of the printer:

- Serial communications port
- Parallel port
- I/O board port (if you have an adapter card installed)

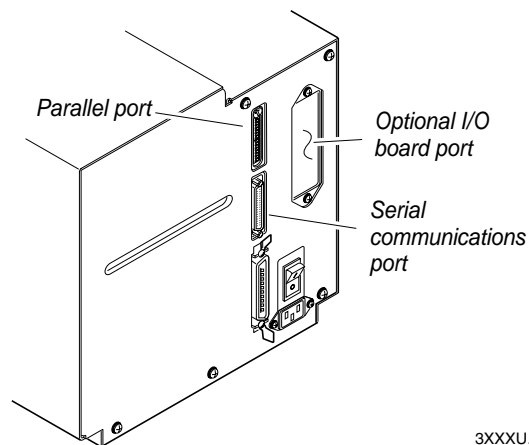

3XXXU.008

Printer ports: This illustration shows you where to connect your system to the printer.

Connecting Your Printer to a PC

You can connect your printer to either a serial port or parallel port on your PC. You must provide the correct cables for connecting the printer. See the following sections for cable information. Contact your Intermec representative for ordering assistance if you do not have the appropriate cables.

Connecting the Printer to a PC Serial Port

To connect the printer to your PC serial port, you need a shielded EIA RS-232, RS-422, or RS-485 electrical interface with a 25-pin D-style subminiature connector. It must have pins on the printer end and an appropriate serial port connector on the other end.

To connect to an IBM PC, you can use these Intermec cables:

- 25-pin printer to 25-pin serial port null modem (P/N 048668)
- 25-pin printer to 9-pin serial port null modem (P/N 048693)

You cannot order an Intermec cable for the RS-422 interface, but there is a schematic on page 94 in Appendix C that you can use to purchase or make your own cable. Also see Appendix C for the RS-232, RS-422, and RS-485 serial port pin assignments.

To connect your printer to a PC serial port

- 1 Turn the On/Off switch to the off position.
- 2 Plug the 25-pin connector into the serial communications port on the rear of the printer.
- 3 Plug the other end of the cable into a serial (COM) port on the PC.
- 4 If necessary, change the PC serial port configuration to match your printer. See “Configuring the Serial Port for Communications” on page 12 for more information.

Connecting the Printer to a PC Parallel Port

If you are using a parallel port to communicate with your printer, you need a parallel cable to run between the printer and the PC.

You can purchase a parallel cable from Intermec (P/N 051211) or from your local computer store. See page 70 in Appendix A for pin descriptions of the parallel cable connector.

To connect your printer to a PC parallel port

- 1 Turn the On/Off switch to the off position.
- 2 Plug the parallel interface connector into the parallel communications port on the rear of the printer.
- 3 Plug the other end of the cable into a parallel port on the PC.

Connecting Your Printer to a Network

You can connect the printer to Novell NetWare networks, Token Ring networks, or other TCP/IP networks. To connect the printer to a network, you must have a network interface adapter (for example, Ethernet). The network interface adapter connects to the 10i port of the printer. Your network must be able to use XON/XOFF (software and hardware flow control) protocol.

If you need to change the printer's communications parameters, follow the procedures in "Configuring the Serial Port for Communications" on page 12.

Connecting the Printer to an AS/400

To connect a printer directly to an AS/400 or other midrange computer, you need:

- a twinax adapter card.
- a twinaxial cable equivalent to IBM part number 7362267 or 7362062. The maximum cable length for the twinax interface is 1,525 meters (5,000 feet).

If you did not have the twinax card installed at the factory, a field service technician can install the field installable option (P/N 056835) in the optional I/O board port of your printer.

For help on cabling and communications, see the manual that comes with the twinax adapter card.



Note: If you are using a midrange computer other than the AS/400, refer to your system documentation for information on cabling and setting up communications.

Connecting the Printer to a Mainframe

To connect the printer directly to an IBM mainframe, you need:

- a coax adapter card.
- a coaxial cable equivalent to IBM part number 2577672 or 1833108.

The maximum cable length allowed is 1,500 meters (4,920 feet). See the IBM specification *Installation and Assembly of Coaxial Cable and Accessories*, part number GA27-2805-4, for further information.

For help on cabling and communications, see the manual that comes with your coax adapter card.

Cabling in Noisy Electrical Environments

The items listed below create noisy electrical environments that can disrupt data communications between your host computer and the printer:

- Large power transformers
- Large electrical motors
- Arc welders
- Motor controllers
- Switch gears

If any of these items are near your printer, you may want to try the following suggestions to reduce the effects of electrical noise:

- Always use shielded cable. Connect the cable and shield to the metal backshells on the cable connectors and fasten the connectors to the serial ports using screws.
- Install ferrite cable clamps.
- Connect the printer chassis ground to the building ground. You will find the chassis ground on the ground pin of the printer power cord.

If you need help eliminating electrical noise, ask your Intermec representative for assistance.

Configuring the Serial Port for Communications

You need to configure the serial port of the printer to match the configuration of your PC or network controlling device. If the printer's default settings do not match, use the DIP switch settings table to configure the serial port.

To configure the printer serial port

- 1 Use the following DIP switch setting descriptions and table to locate the DIP switches you need to change to configure the serial port.
- 2 Use a small straight-slot screwdriver to set the appropriate DIP switches.
For example, if you want to change the media type to thermal transfer, set DIP switch 8 on the bottom bank of switches to the on position.
- 3 Turn the printer power off and then on for the configuration changes to take effect.



Note: Ignore Multi-Drop switches if you are not using a Multi-Drop network.

DIP Switch Setting Descriptions

Parameter	Description
Baud rate	The rate, in bits per second, at which the host exchanges data with the printer. The maximum baud rate is 115,200.
Parity	Adds one bit (1 or 0) to the character to make the sum of bits always odd or even.
Number of Data bits	The number of bits that represent the ASCII characters.
Multi-Drop address	Unique address for each device connected with Multi-Drop protocol.
Protocol	The transmission standards for communication between the printer and each connecting device.
XON/XOFF	The protocol that stops the host from sending data when the printer buffer fills up and starts it again when the buffer empties.
Media type	Enables the printer to work with either direct thermal or thermal transfer media.

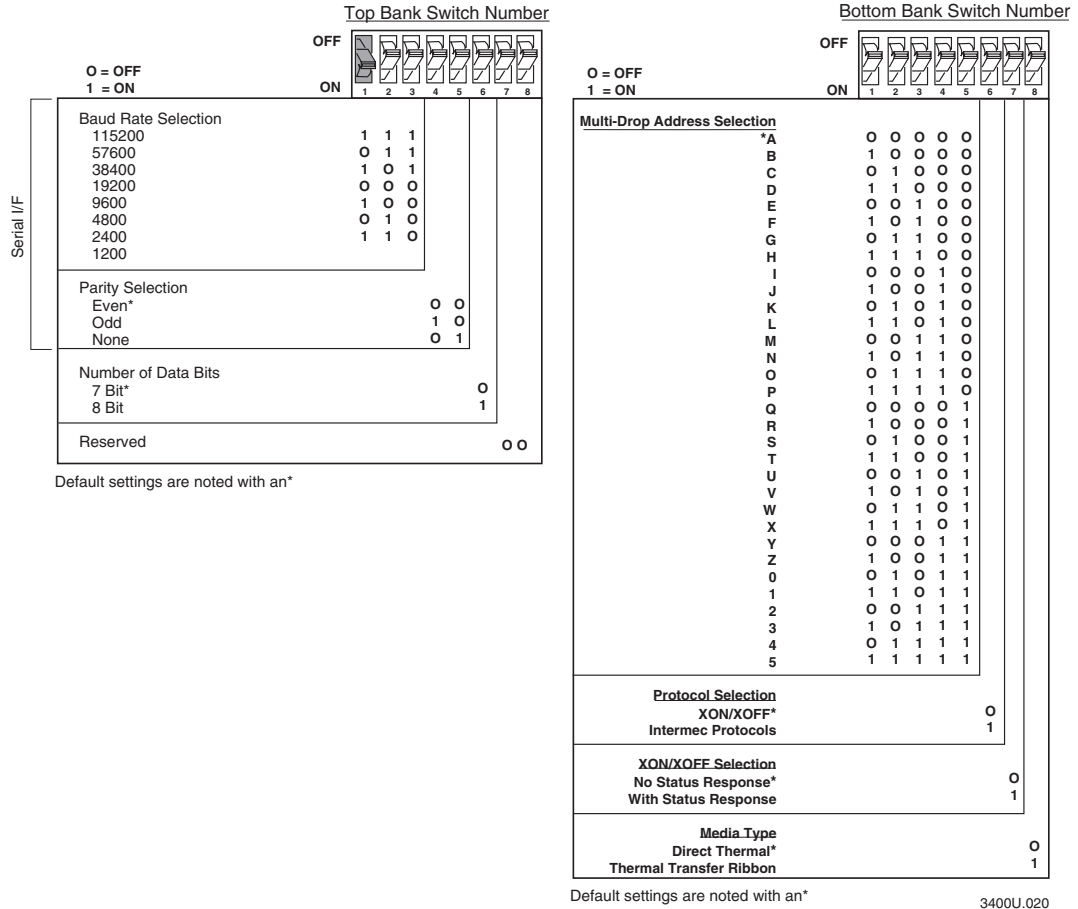

DIP switch settings: These charts illustrate the settings for the DIP switches on the top and bottom banks. For a description of each setting, see the DIP Switch Settings Descriptions table on page 12.

Verifying Printer Communications With Your System

After connecting the printer to your system, you need to test communications. The easiest way to test communications is to set the printer to Data Line Print mode, which is part of Test and Service mode, and send a character string down from your system.

To verify communications with your system

- 1 If you have just printed a configuration test label, you are already in Data Line Print mode. Go to Step 5.
- 2 Turn the On/Off switch to the off position.
- 3 Press and hold the Feed/Pause button while you turn the On/Off switch to the on position. The printer prints the hardware configuration test label.
- 4 Release the Feed/Pause button. You are now in Data Line Print mode.

- 5 Transmit at least four characters from your system.

At this point, the printer does not attempt to interpret any printer commands, but simply prints each character with its hexadecimal equivalent underneath.



Note: An example of using DOS to verify printer communications follows this procedure.

- 6 To enter normal Print mode, turn the printer power off and then on again.

If this procedure does not work, make sure that the DIP switches match the serial port configuration of the system and that you have the printer cable securely plugged into the correct port of your system.

If you receive a write fault error, your cabling may not be correct. See “Connecting the Printer to Your System” on page 8 for more information.



Note: Please refer to your host computer user’s manual and the *IPL Programming Reference Manual* for information on downloading commands.

Example of Using DOS to Verify Printer Communications

- 1 At the DOS prompt, type this command and press **Enter**:

```
MODE COM1 96,E,7,1,N
```

- 2 Type these command lines and press **Enter**:

```
COPY CON COM1  
ABCDEF^Z
```

where:

COPY CON COM1 has the PC copy the following information to the COM1 port.

ABCDEF are random characters entered at the host.

^Z (**Ctrl-Z**) **Enter** sends the information to the printer.

The printer will print these characters:

```
A B C D E F  
41 42 43 44 45 46
```

3XXXU.021



Note: If you are using a different platform to communicate with your printer, please refer to your host computer user’s manual and the *IPL Programming Reference Manual* for help downloading commands.



2 Operating the Printer

This chapter describes how to use the printer. This chapter covers these topics:

- Understanding the front panel
- Loading roll media and media for self-strip printing
- Loading thermal transfer ribbon
- Setting the media sensitivity number
- Communicating with the printer

Learning How to Operate the Printer

To operate the printer, you need to understand:

- how light emitting diodes (LEDs) help you monitor the status of the printer and the various tasks the Feed/Pause button performs.
- how to load roll media, thermal transfer ribbon, and the procedure for using the self-strip option.
- how to optimize print quality and print speed.
- different methods for transferring information from the host to the printer and from the printer to the host.

Understanding the Front Panel

Use this section to understand the function of the front panel LEDs and the Feed/Pause button.

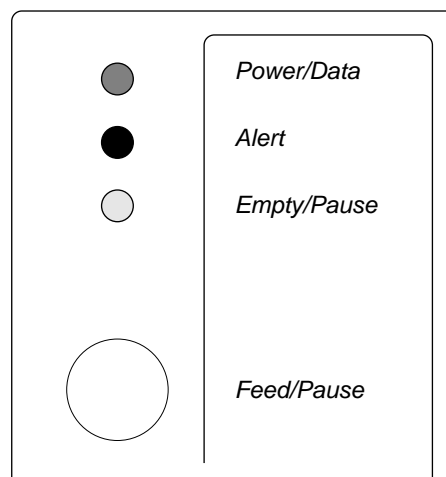

3XXXU.024

Front panel: This illustration shows the front panel LEDs and the Feed/Pause button.

Understanding the Front Panel LEDs

You can use the front panel LEDs to monitor the status of the printer and troubleshoot the printer.

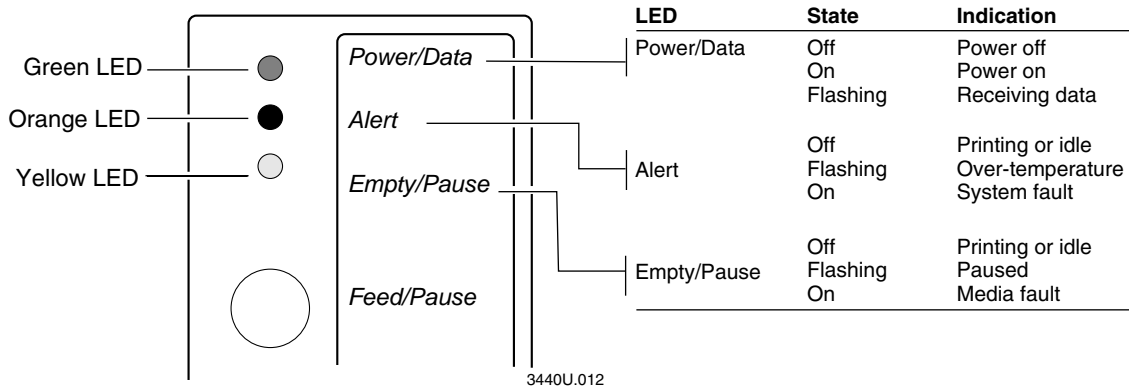

LED states: This illustration shows what each LED state indicates.

LED States for Problems

Problem	LED State
Over-Temperature	If the printer overheats, the Alert LED flashes and the printer stops. Do not try to troubleshoot or adjust the printer—just allow the printer enough time to cool down and it will resume operation on its own.
Media or System Faults	If the Empty/Pause or the Alert LED remains on, your printer is experiencing a media or system fault. For help, see Chapter 4, “Troubleshooting.”

Using the Feed/Pause Button

The Feed/Pause button, located on the front of the printer, performs several functions depending on the mode of the printer.

Feed/Pause Button Functions

Printer Mode	You Want To	What to Do
Idle	Feed out one label or a minimum specified amount of media.	Press and release the Feed/Pause button.
	Continuously feed media.	Press and hold the Feed/Pause button. When you release the button, the media stops feeding.
	Take the printer offline.	Press the Feed/Pause button twice. Press the button again to bring the printer online.
Printing	Pause the printer.	Press and release the Feed/Pause button. Press and release the button again to resume printing.
	Cancel the current print job.	Press and hold the Feed/Pause button until the printer stops printing.

Feed/Pause Button Functions (continued)

Printer Mode	You Want To	What to Do
Turned on for the first time	Print the hardware configuration label.	Press and hold the Feed/Pause button. See “Printing the Hardware Configuration Test Label” on page 7 for more information.

Loading Media Into the Printer

You can load media into the printer in three different ways:

- Straight-through printing with roll media
- Self-strip printing with roll media (optional)
- Fanfold printing (see page 5)

You can load media with the printer power turned on or off. The following procedures for loading media assume that you have turned the printer on.

Loading Roll Media for Straight-Through Printing

In straight-through printing, you load a roll of media on the supply roll post and feed it straight through the printer mechanism and out the front of the printer. As the printer completes the printing of individual labels, you can remove them from the roll by pulling them down across the tear bar.



Note: This procedure covers how to load media for straight-through print mode using a roll of direct thermal or thermal transfer label media. The default setting for the printer is direct thermal mode; use PrintSet to change the printer to thermal transfer mode.



Note: You should find a small label with a three-digit sensitivity number printed on it attached to your roll of media or a 15-digit number stamped on the side of the media roll (Intermec media only). Save this information. You will need it to set the correct media sensitivity number. See “Setting the Media Sensitivity Number” on page 24 for help.

To load the media

- 1 Raise the printhead by rotating the head lift lever clockwise until the printhead disengages.
- 2 Turn the supply roll retainer counterclockwise to release it, and then slide it to the outer end of the supply roll post.

If you are replacing the empty media roll with a new roll of the same width, you do not need to adjust the edge guide or the supply roll retainer.

- 3 Place the media roll on the supply roll post and position it firmly against the printer.

If you are using a narrow roll of media, less than 7.62 centimeters (3 inches), insert the media support between the roll of media and the supply roll retainer before securing it.

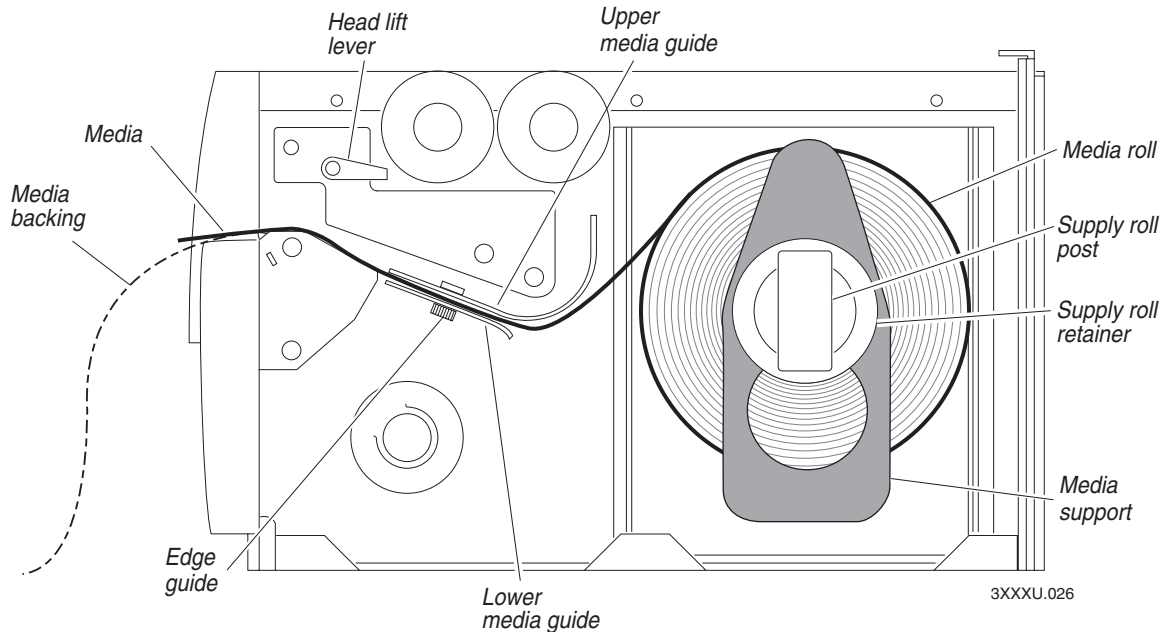

- 4 Slide the supply roll retainer up to the edge of the media roll and turn the supply roll retainer clockwise to secure.
- 5 Pull down on the lower media guide to allow easy access to the media path. Make sure that the edge guide slides all the way to the outer edge of the lower media guide.
- 6 Insert the label stock through the printer mechanism as shown. Make sure the label passes between the upper and lower media guides. The front edge of the media should pass over the tear bar and out the front of the printer.
- 7 Release the lower media guide and adjust the edge guide to position the media firmly against the inside wall of the printer.

If you are using thermal transfer media, refer to “Loading Thermal Transfer Ribbon” on page 22 before you finish performing this procedure.

- 8 Lower the printhead by rotating the head lift lever counterclockwise until it locks.

- 9 Use PrintSet, your third-party software, or the IPL command set to configure the printer for the kind of media you are using (continuous or mark label). Refer to the PrintSet online help, your third-party documentation, or the IPL Programming Reference Manual for help.
- 10 Press Feed/Pause to advance several inches of media through the printer and out the label opening in the front cover. Your printer is now ready to print labels.



Note: Refer to the label located on the inside of the media cover for directions on loading media. For your convenience, you may want to refer to it when loading media in the future.

Loading Media for Self-Strip Printing

Use self-strip printing in applications where you want to apply labels to a surface immediately. After printing a label, the printer prints out the label with the backing removed. The rewinder hub collects the backing after it passes over the self-strip assist roller. The rewinder hub can hold the backing from an entire roll of media.



Note: You should find a small label with a three-digit sensitivity number printed on it attached to your roll of media or a 15-digit number stamped on the side of the media roll. Save this information. You will need it to set the correct media sensitivity number. See “Setting the Media Sensitivity Number” on page 24 for help.

To load self-strip media

- 1 Raise the printhead by rotating the head lift lever clockwise until the printhead disengages.
- 2 Turn the supply roll retainer counterclockwise to release it and slide it to the outer end of the supply roll post. Turn it clockwise to lock it in place.
- 3 Place the media roll on the supply roll post and position it firmly against the inside wall of the printer.
- 4 Turn the supply roll retainer counterclockwise and slide it up to the edge of the media roll. Turn the supply roll retainer clockwise to secure.



Note: If you are using a narrow roll of media, less than 7.62 centimeters (3 inches), insert the media support between the roll of media and the supply roll retainer before securing it.

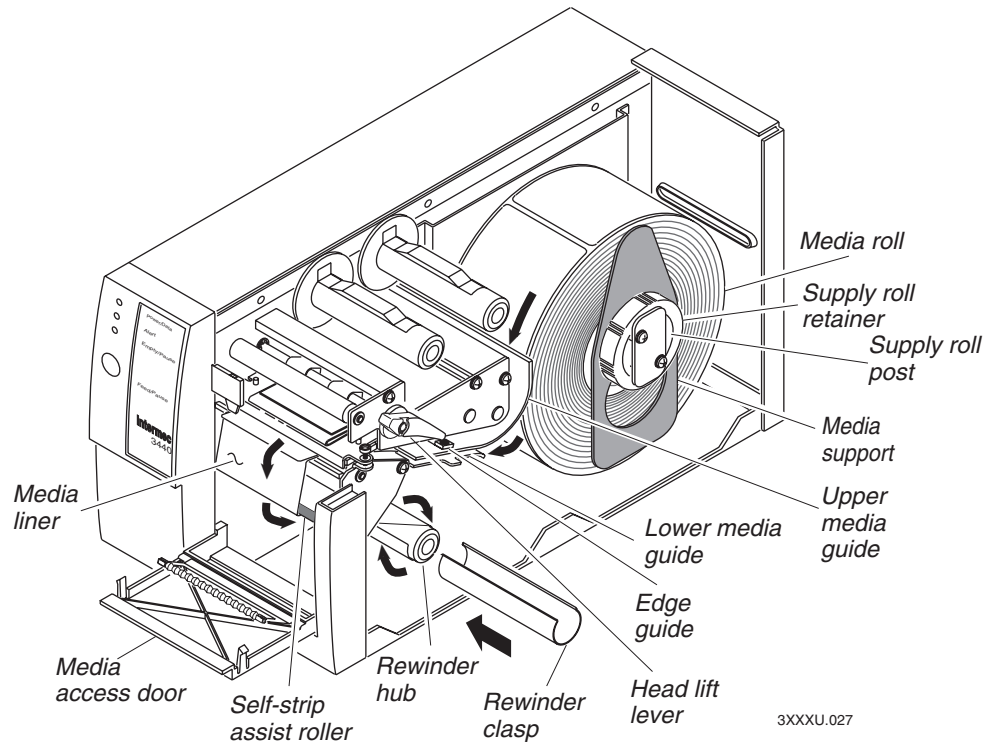

- 5 Unscrew the edge guide and slide it to the outer edge of the lower media guide. Screw it in place.
If you are replacing the empty media roll with a new roll of the same width, you do not need to adjust the edge guide.
- 6 Pull down on the lower media guide to allow easy access to the media path.
- 7 Unroll several inches of media, insert it between the upper media guide and the lower media guide, and out the front of the printer.
- 8 Release the lower media guide and adjust the edge guide to position the media firmly against the inside wall of the printer.
- 9 Pull out 25.4 to 30.48 centimeters (10 to 12 inches) of media and remove the exposed labels from the media liner.
- 10 Open the media access door and thread the media liner under the self-strip assist roller and over the rewinder hub in a clockwise direction.
- 11 Remove the rewinder clasp from the rewinder hub and wind approximately 5.08 centimeters (2 inches) of media liner clockwise over the rewinder hub.
- 12 Secure the media to the rewinder hub by snapping the rewinder clasp onto the rewinder hub. Turn the rewinder hub clockwise to remove all slack from the media liner between the tear bar and the rewinder hub.
- 13 Close the media access door.
- 14 Rotate the head lift lever counterclockwise until it locks.

- 15 Use PrintSet, your third-party software, or the IPL command set to enable self-strip and the label taken sensor. Refer to the PrintSet online help, your third-party documentation, or the IPL Programming Reference Manual for help.
- 16 Press the Feed/Pause button to advance a label through the printer. Grasp the leading edge of the label where it has separated from the backing and pull it away from the printer.
- 17 Replace the printer cover. The printer is now ready to print labels.

Loading Thermal Transfer Ribbon

If you plan to use thermal transfer mode, you must install a thermal transfer ribbon (TTR) to print in thermal transfer mode.



Note: Save the packaging that your ribbon came in. Attached to the ribbon packaging is a small label with a three-digit sensitivity number printed on it (Intermec ribbon only). You need this information to set the correct media sensitivity number. Refer to the next section “Setting the Media Sensitivity Number” for more information.

The core of your thermal transfer ribbon is either made of cardboard or plastic. You need to use the correct core-locking brackets for your ribbon core. The printer ships from the factory with the cardboard core-locking brackets already attached.



Note: If you do not use the correct core-locking brackets, you may experience printing problems or possible damage to the printer.

To change the cardboard core-locking brackets to plastic core-locking brackets

- 1 Pull up on the middle of the cardboard core-locking bracket (P/N 065375), while pushing down on one end with your index finger, until the end of the bracket is free of the ribbon hub.

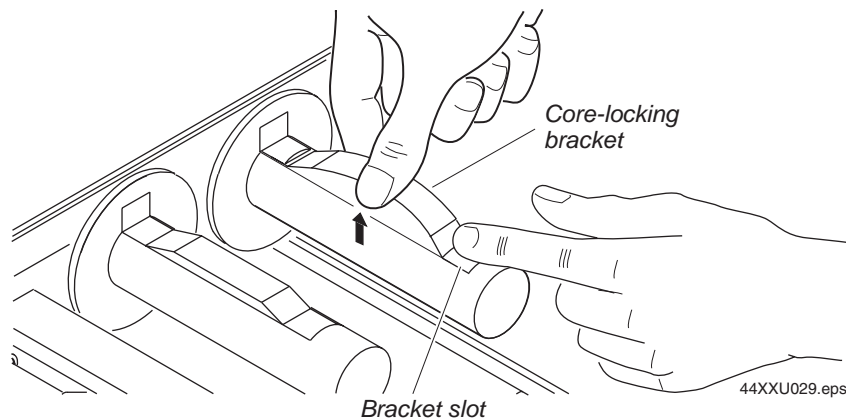

- 2 Remove the other end of the bracket from the ribbon hub.
- 3 Slide one end of the plastic core-locking bracket (P/N 066792) into a bracket slot on the ribbon hub.
- 4 Lift up on the middle of the bracket and use your index finger to slide the other end of the bracket into the remaining bracket slot on the ribbon hub.

To load thermal transfer ribbon

- 1 Raise the printhead by rotating the head lift lever clockwise until the printhead disengages.
- 2 Place the empty ribbon core that came with the printer onto the ribbon rewind hub.
- 3 Detach the leader from the new thermal transfer ribbon roll and unwind the end of the ribbon approximately 20.32 centimeters (8 inches). The edge of the ribbon has a leader (with an adhesive strip on the leader edge) for guiding the ribbon through the printhead mechanism.
- 4 Slide the roll of thermal transfer ribbon onto the ribbon supply hub with the ribbon roll winding clockwise.

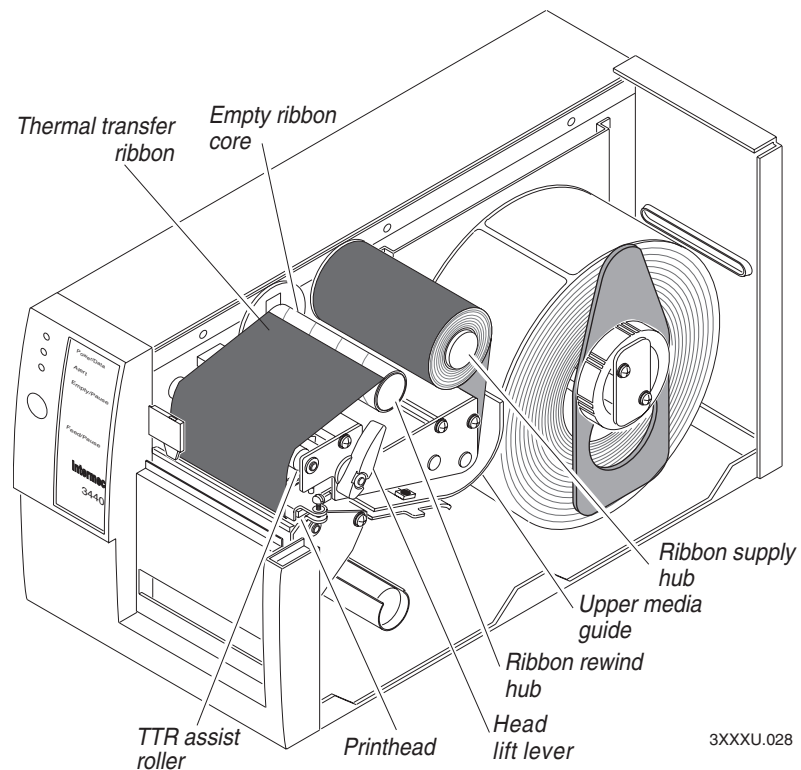

- 5 Route the ribbon leader through the printer mechanism as shown in the previous illustration.



Note: Make sure the ribbon runs above the upper media guide. The shiny side of the ribbon must come in contact with the printhead.

- 6 Attach the leader from the new thermal transfer ribbon roll to the empty ribbon core using the adhesive strip on the leader edge.
- 7 Wind the ribbon rewind hub clockwise until the ribbon runs smoothly through the printhead mechanism and the leader moves past the printhead.
- 8 Rotate the head lift lever counterclockwise until it locks.
- 9 Enable thermal transfer printing by setting DIP switch 8 on the bottom bank of switches to the on position. For help, see “Configuring the Serial Port for Communications” on page 12.
- 10 Press the Feed/Pause button to advance the ribbon through the printer.
- 11 Close the printer. The printer is now ready to print.



Note: When replacing the thermal transfer ribbon roll in the future, use the empty ribbon supply core as the new rewinder core.

Setting the Media Sensitivity Number

Media sensitivity is important because you use it to optimize print quality and print speed. The three-digit media sensitivity number (MSN) specifies the amount of heat required by the printhead to image a label. The amount of heat that each roll of media or ribbon requires is unique due to different chemistries and manufacturing processes.

Intermec has developed heating schedules (the amount of heat required to image a label) to produce the highest possible print quality for Intermec media and ribbon combinations on Intermec printers. You can achieve the best print quality on the printer by using only Intermec ribbon and media products. This table lists the default MSN:

Default MSNs

Media Type	Default
Direct thermal media (2 to 5 ips)	470
Direct thermal media (6 to 8 ips)	720
Thermal transfer media (2 to 10 ips)	567

If you need to determine an MSN, obtain the part number of your media and call 1-800-755-5505, press 1 and then 1. The part number may be printed on the outside of the box carton.

Use the PrintSet software, your third-party software, or the IPL command set to change the MSN. If you want to see the current sensitivity setting of your printer, print out a software configuration label.

To print a software configuration label

- 1 Turn the On/Off switch to the off position.
- 2 Press and hold the Feed/Pause button while turning the printer on. The printer prints out a hardware configuration label.
- 3 Set the DIP switches to print out the software test label.

Top Bank	Set switches 1 through 6 and 8 off. Set switch 7 on.
Bottom Bank	Set switches 1 through 8 off.
- 4 Hold the Feed/Pause button down for 1 second. The printer prints out the software configuration label.
- 5 Return the DIP switches to their original settings.
- 6 Turn the printer power off and then on.

Setting the MSN for Intermec Media and Ribbon

For direct thermal media, use the three-digit sensitivity number located on the roll of media to set the sensitivity number. You can also use the values from the tables in the next section.

For thermal transfer media, you need to look in two places to determine the sensitivity number. The sensitivity number on each roll of thermal transfer media or ribbon has an asterisk (*) in place of one of the digits. On thermal transfer media, the rating contains the first and second digits, with an asterisk in place of the third digit. The number on the ribbon has the first and third digits, with an asterisk in place of the second digit.

To optimize the sensitivity number for thermal transfer media, you combine the digits as in this example.

Example: Optimizing the Sensitivity Number

Media or Ribbon	Sensitivity Number	Description
Thermal transfer media	56*	The asterisk reserves the third digit to identify the ribbon's sensitivity number.
Thermal transfer ribbon	5*7	The asterisk reserves the second digit to identify the media's sensitivity number.
	567	Optimized sensitivity number

Setting the MSN for Other Media and Ribbon

If you are not using Intermec media and ribbon, or you misplaced your packaging with the three-digit sensitivity number label on it, you can set the approximate sensitivity number. The first column of the Direct Thermal and Thermal Transfer Media Sensitivity Settings tables list the approximate sensitivity settings. To achieve acceptable print quality, enter the three-digit MSN (for example, 800).

If you are unsure of how to set the MSN, start with the highest setting, which provides the lowest energy (800 for thermal transfer and 700 for direct thermal), and work your way down until you achieve the best print quality. You can also use PrintSet's Print Quality Wizard to help achieve print quality.

Direct Thermal Media Sensitivity Settings

Approximate Sensitivity Numbers	Sensitivity Setting	Direct Thermal Media	Maximum Recommended Print Speed
700 Series High Sensitivity	720	Duratherm Lightning Plus - 2	8
400 Series Medium Sensitivity	480	Duratherm Lightning IR Tag	5
	470	Duratherm Lightning - 1	5
	460	European IR	5
	450	Duratherm Lightning IR Labels - 1	5
	440	European Thermal	5
	420	Duratherm Lightning Labels - 1	5
100 Series Low Sensitivity	180	Duratherm II - 1	3
	170	European Tag	3
	160	Duratherm II Tag	3
	140	European Top	3
	130	Duratherm II - 2	3
800 Series High Sensitivity (Paper)	864	European Uncoated/Standard - 1	8
	854	Duratran TTR Paper Labels/Standard - 1	6
	834	Duratran TTR Paper Tags/Standard - 1	6

Direct Thermal Media Sensitivity Settings (continued)

Approximate Sensitivity Numbers	Sensitivity Setting	Direct Thermal Media	Maximum Recommended Print Speed
600 Series Medium Sensitivity (Paper)	687	Duratran TTR Polyester 1/Premium - 7	6
	677	Duratran Syntran/Premium - 7	6
	633	European Polyethelene/Premium	8
	627	Duratran Kimdura/Premium - 7	8
	623	Duratran Kimdura/Premium	6

Thermal Transfer Media and Ribbon Sensitivity Settings

Approximate Sensitivity Numbers	Sensitivity Setting	Direct Thermal Media	Maximum Recommended Print Speed
500 Series Medium Sensitivity (Paper)	567	Duratran II-1/Premium - 7	8
	565	European Premium Paper/Premium	4
	563	Duratran II-1/Premium	7
	533	European Tag/Premium	6
	527	Duratran II Tag - 7 mil/Premium - 7	6
	513	European Coated/Premium	6
300 Series Low Sensitivity (Plastic)	369	Super Premium Poly./Super Premium - 3	5
	366	Super Premium Poly./Super Premium - 7	5
200 Series Low Sensitivity (Kapton)	238	Gloss Polyimide (Kapton)/Gloss Super Premium	3
	236	Gloss Polyimide (Kapton)/Super Premium-7	3
	226	Matte Polyimide (Kapton)/Super Premium-7	3
	222	Matte Polyimide (Kapton)/Matte Super Premium	3

Communicating With the Printer

You are now ready to print labels by downloading data from the host to the printer. *Downloading* is the universal term used to describe the transfer of information from the host to any connected peripheral device, such as your printer. When you transfer data from your printer to the PC or host, you are performing a process called *uploading*.

You can use several methods to download information in your data collection system. The next sections describe different ways to communicate with the printer.

Using the PrintSet Software

Use the PrintSet application software to easily configure your printer from your PC. You can upload the current configuration settings, modify them, and then download them to your printer.

PrintSet also lets you:

- download graphics and fonts.
- print test labels using resident fonts, user-defined bitmap graphics, or resident bar code symbologies.
- allocate printer memory.
- download configuration files to multiple printers.
- use flash-based firmware (e series).

For help using PrintSet, refer to the online help portion of the application software.

Using Third-Party Software

You can use third-party software to set many of the printer parameters. You can configure the parameters that your software does not set by using the printer command set or the configuration DIP switches.

Use your third-party software to create label formats and convert graphics into a user-defined character (UDC) format that the printer can interpret. Refer to your third-party documentation and the *IPL Programming Reference Manual* (P/N 066396) for more information.

Using Intermec Printer Language (IPL) Commands

You can create labels by downloading formats (designs) and data with IPL commands. You can use the printer to perform any function or activate any feature of the printer except for those features or functions that you set with the DIP switches. See the *IPL Programming Reference Manual* for more information.

Printing a Test Label

If you would like to test your communications by downloading a label, follow the example below. Use the PrintSet application software to send a test label to the printer. This example assumes that your printer is communicating with a PC and that the printer is correctly loaded with media.

To print the test label

- 1 Start PrintSet on your PC.
- 2 From the Options menu, choose Test Print.
- 3 Select the Test Label option button.
- 4 Select either the Text or the Bar Code option button.

If you select to print text, you can choose any font in the Select Printer Font list box.

If you select to print a bar code, you can choose any symbology in the Select Symbology list box.

- 5 Choose Print. Your attached printer prints a test label.

For example, if you chose to print a bar code with the Code 39 symbology, your printer prints a label similar to this one:

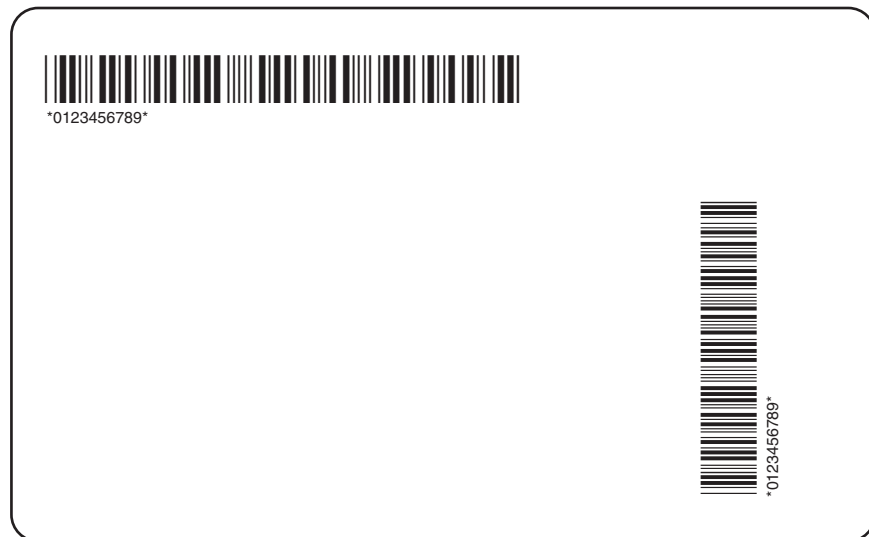

3XXXU.030



3 Maintaining the Printer

This chapter explains how to clean and maintain the printer. Even though the printer can withstand harsh environments, you must clean it on a regular basis to maximize performance. It is very important to perform the maintenance procedures if you expose the printer to dirt or debris. This chapter covers these topics:

- Inspecting the printer
- Tools for cleaning the printer
- Maintenance schedule
- Cleaning the printhead
- Cleaning the printer covers
- Cleaning the drive roller and tear bar
- Cleaning the media guides and media path
- Cleaning the label sensors

Inspecting the Printer

Inspect the printer and the rest of your data collection system equipment on a regular basis. Your inspection should include the following:

- Make sure you have properly grounded the printer.
- Inspect the work environment. Large electric motors, welders, and switching equipment can affect printer performance.
- Keep the printer away from liquids.
- Check the data collection network regularly for loose wires or poorly installed connections. Be sure to replace corroded wires.

Tools for Cleaning the Printer

To clean the printer safely and effectively, use the following items:

- Isopropyl alcohol
- Cotton swabs
- Clean lint-free cloth
- Vacuum cleaner
- Soapy water/mild detergent
- Cleaning card (P/N 1-110501-00)

The following procedures explain how to access the printer parts and clean them without causing any harm to the printer or yourself.

Maintenance Schedule

Clean your printer regularly to maintain the quality of your labels and extend the life of your printer. This table contains suggestions for cleaning the printer. Use the illustration on the next page to locate the parts you need to clean.

Printer Maintenance Schedule

Printer Component	Maintenance Period
Thermal printhead	Inspect after every roll of media or ribbon. Clean after every roll, or 15,240 centimeters (6,000 inches), of media or more often if necessary.
Printer Cover	Clean as necessary.

Printer Maintenance Schedule (continued)

Printer Component	Maintenance Period
Drive roller and tear bar	Clean after every five rolls of media. If you are using hi-tack adhesive, you must clean after every roll of media. If you are using tag stock or continuous media, you may want to clean after every five rolls of media or as necessary. Clean more often in environments that are harsh or dusty.
Media path (not shown)	
Edge guide	
Upper media guide	
Lower media guide	
Thermal transfer ribbon (TTR) assist roller	
Self-strip roller	
Label gap sensor (not shown)	
Label mark sensor (not shown)	
Label taken sensor	
Pinch roller	

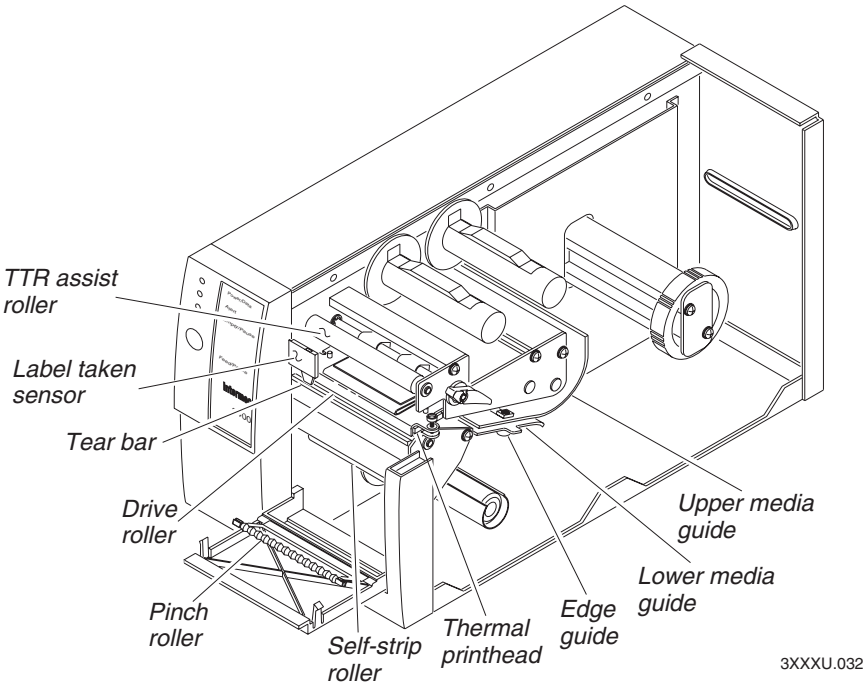

Printer parts: This illustration shows the printer parts that need to be cleaned. For a maintenance schedule of each part, see the Printer Maintenance Schedule table earlier in this chapter.



If you open the electronics cover, you will void the warranty and may cause damage to the internal components. Opening the electronics cover exposes the user to shock hazards which may result in injury or death.

Avertissement: L'ouverture du couvercle du boîtier des composants électroniques entraînera l'annulation de la garantie, et peut endommager les composants internes. L'ouverture du couvercle du boîtier des composants électroniques expose l'utilisateur à des risques d'électrocution qui peuvent résulter par les blessures ou la mort.



Switch off the printer power and remove the power cord before cleaning any part of the printer.

Avertissement: Mettez l'imprimante hors tension et débranchez le câble d'alimentation avant de nettoyer une partie de l'imprimante.

Cleaning the Printhead

In order for the printhead to provide good print quality, it must maintain close contact with the media. Therefore, cleaning media debris from the printhead is very important. Clean after every roll, or 15,240 centimeters (6,000 inches), of media or when necessary. There are two ways to clean the printhead:

- Use the cleaning card.
- Use a cotton swab and isopropyl alcohol.



Do not use sharp objects such as knives or screwdrivers to scrape the printhead clean. Cleaning with sharp objects will damage the printhead. Clean with only a cotton swab, or a clean, lint-free cloth or tissue damp with isopropyl alcohol.

Attention: N'utilisez pas d'objets pointus tels que couteaux ou tournevis pour nettoyer la tête d'imprimante. Nettoyer avec des objets pointus endommagera la tête d'imprimante. Nettoyez-la seulement avec de la ouate ou avec un linge propre et libre de peluches, humecté avec de l'alcool d'isopropyl.

To clean the printhead using the cleaning card

- 1 Turn off the printer and remove the power cord.
- 2 Remove the media cover.
- 3 Disengage the printhead by rotating the head lift lever clockwise until the printhead releases. This raises the printhead so that you can clean it.
- 4 Remove the media and ribbon.
- 5 Open pouch and remove cleaning card.

- 6 Insert cleaning card into the printer following the media path.

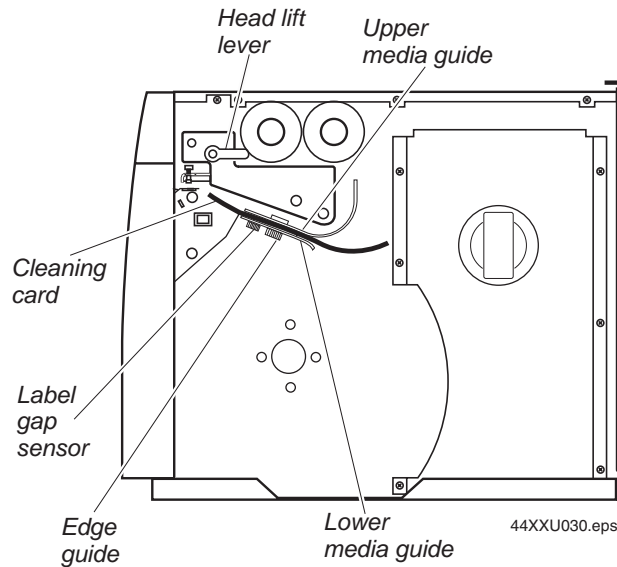

- 7 Engage the printhead by rotating the head lift lever counterclockwise until it locks in place.
- 8 Use one hand to hold the printer and use the other hand to pull the cleaning card forward until you have pulled the entire card through the media path.
- 9 Repeat Steps 6 through 8.
- 10 Dispose of the cleaning card properly.
- 11 If you are finished cleaning, replace the media cover.

To clean the printhead using a cotton swab and isopropyl alcohol

- 1 Turn the On/Off switch to the off position and remove the power cord.
- 2 Remove the media cover.
- 3 Rotate the head lift lever clockwise until the printhead releases. Rotating the head lift lever raises the printhead to allow for cleaning.
- 4 Remove the media and ribbon (if necessary).
- 5 Use a cotton swab moistened with alcohol to remove any dirt, adhesive, or debris from the print surface on the bottom of the printhead.

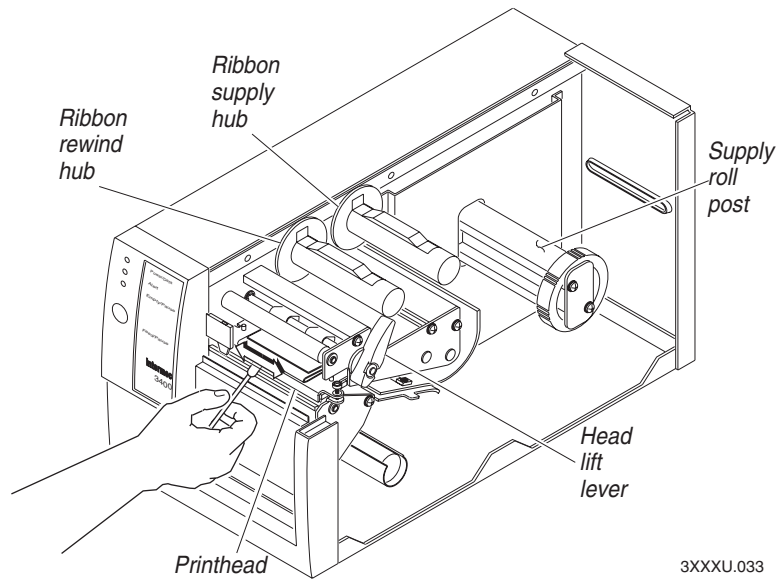

3XXXU.033

- 6 Wait 5 to 10 seconds for the print surface to dry. Replace the media and ribbon.
- 7 Engage the printhead by rotating the head lift lever counterclockwise until it locks in place.
- 8 If you are finished cleaning, replace the media cover.

Cleaning the Printer Covers

Use a general purpose cleaner (soapy water/mild detergent) to clean the printer covers. Do not use abrasive cleansers or solvents. Be sure to clean the transparent panel on the media cover so that the media supply inside the printer is visible when you close the cover.

Cleaning the Drive Roller and Tear Bar

Cleaning the drive roller and tear bar preserves print quality by maintaining close contact between the media and the printhead.

To clean the drive roller and tear bar

- 1 Turn the On/Off switch to the off position and remove the power cord.
- 2 Remove the media cover.
- 3 Rotate the head lift lever clockwise to release the printhead.
- 4 Remove the media and ribbon (if necessary).
- 5 Clean the drive roller by using a cloth dampened with isopropyl alcohol. Move the cloth over the drive roller in a side-to-side motion as shown. Make sure to rotate the roller so that you can clean all areas.



Note: Rotating the TTR assist roller toward you enables you to clean the entire drive roller surface.

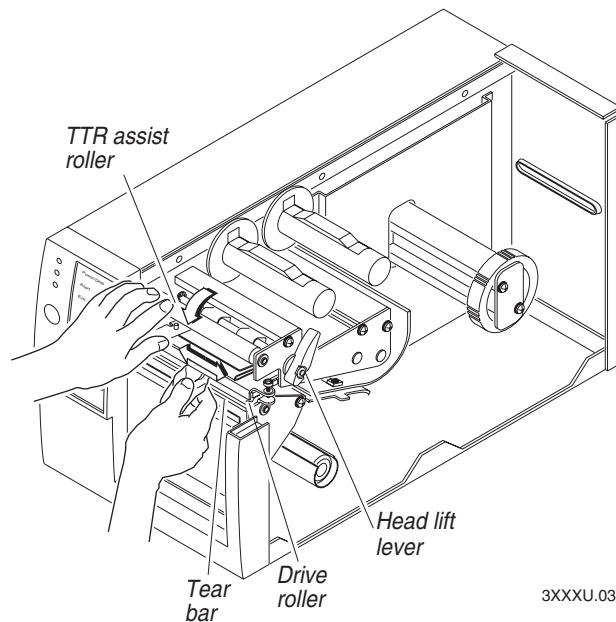

- 6 Clean both sides of the tear bar with a cloth dampened with isopropyl alcohol. Remove all traces of dust, paper, and adhesive.
- 7 Replace the media and ribbon.
- 8 Engage the printhead by turning the head lift lever counterclockwise until the printhead locks.
- 9 If you are finished cleaning, replace the media cover.

Cleaning the Media Guides and Media Path

You should clean the media guides and media path regularly to keep debris off the media surface and printhead where irregularities can spoil print quality or damage the printhead. Cleaning the guides also prevents the media from skewing or improperly tracking as it travels through the paper path which can result in smeared images and print off the side of the label. Always clean the media guides immediately after a label jam in the printer.

To clean the media guides and media path

- 1 Turn the On/Off switch to the off position and remove the power cord.
- 2 Remove the media cover.
- 3 Remove the media and ribbon (if necessary).
- 4 Pull down on the lower media guide to open up the media path.

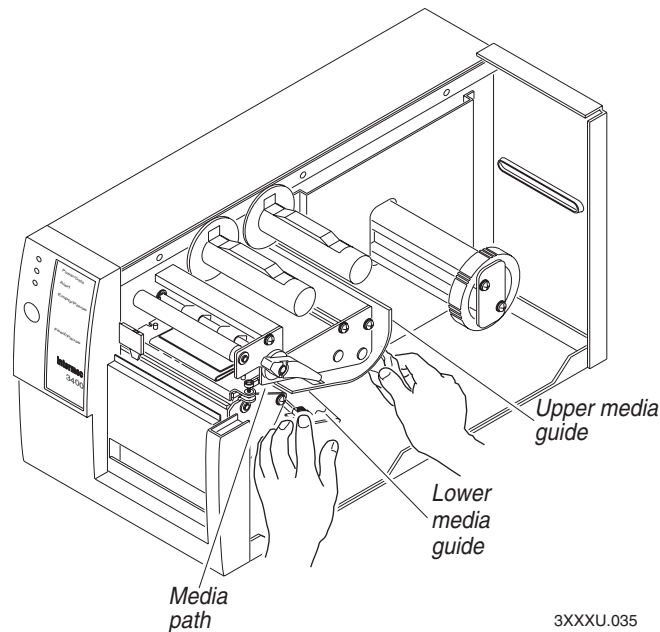

- 5 Use the cloth moistened with isopropyl alcohol to clean the upper and lower media guides. Be sure to remove all traces of debris. Release the lower media guide.
- 6 Remove all traces of dust, paper, and adhesive from the media path with a soft bristle brush or vacuum.
- 7 Replace the media and ribbon.
- 8 If you are finished cleaning, replace the media cover.

Cleaning the Label Sensors

Three label sensors on the printer require regular cleaning:

- Label taken sensor
- Label mark sensor
- Label gap sensor

To clean the label sensors

- 1 Turn the On/Off switch to the off position and remove the power cord.
- 2 Remove the media cover.
- 3 Rotate the head lift lever clockwise to release the printhead. Rotating the head lift lever raises the printhead to allow access to the label mark sensor.
- 4 Remove the media and ribbon (if necessary).
- 5 Clean the label taken sensor with a cotton swab moistened with isopropyl alcohol.

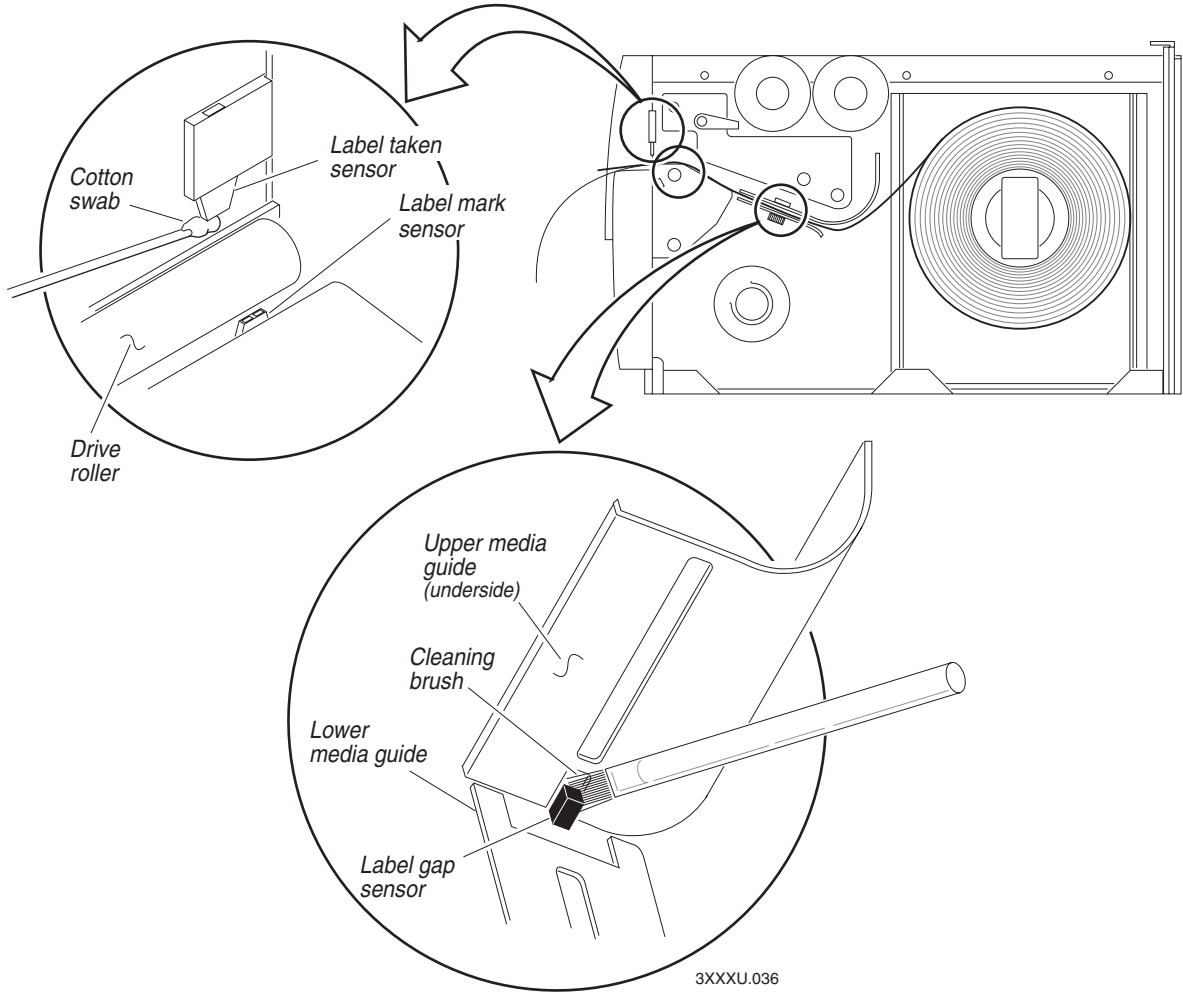

- 6 Pull down on the lower media guide to expose the label gap sensor. Using a cleaning brush or vacuum, remove all debris and dust from the label gap sensor.
- 7 Clean the label gap sensor with a cotton swab and alcohol.
- 8 Replace the media and ribbon.
- 9 Engage the printhead by rotating the head lift lever counterclockwise until it locks in place.
- 10 Replace the media cover.



4 Troubleshooting

This chapter provides some hints for troubleshooting error messages that the printer sends to the host and problems you may experience with the printer. This chapter covers these topics:

- Troubleshooting checklist
- Printer operation problems
- Printer quality problems
- Communication problems
- Preventing data loss

Troubleshooting Checklist

Even though Intermec designed your printer to operate under harsh conditions, you may still encounter a printer operation, print quality, or communication problem at some time. You can easily fix most of the errors you encounter and consequently not delay operation of the printer for very long.

To troubleshoot your printer

- 1 First try cleaning the printer components and checking all of the connections. See Chapter 3, “Maintaining the Printer,” for details.
- 2 If cleaning the printer and checking the connections does not solve the problem, use the following tables to locate the symptom. Follow the solution in the table to fix your problem.

If you receive an error message, refer to the *IPL Programming Reference Manual* (P/N 066396) for a complete list of error messages and their solutions.

If the problem persists, contact your Intermec Customer Service Representative (1-800-755-5505) from North America. If you are an international customer, contact your local Intermec representative.

Printer Operation Problems

If your printer is not operating correctly, try locating the problem in the next table.

Printer Operation Problems

Symptom	Possible Causes	Solution
No power or loss of power.	The AC power cable is damaged or disconnected.	Make sure the power cable is plugged in to both the printer and an outlet or power strip. Replace the cable if damaged.
	Printer circuit breaker tripped.	Turn the printer off, and then back on again.
Labels stop feeding through the printer.	Printer is out of media.	Load new media. For help, see “Loading Media Into the Printer” on page 18.
	The label stock is loaded incorrectly.	Check the media path. For help, see “Loading Media Into the Printer” on page 18.
	The printer is set for continuous label stock.	Use PrintSet to check the configuration settings. If the settings are incorrect, use PrintSet to change the settings.
	Media is sticking to the paper path.	Clean any extraneous material from the paper path and clean the path thoroughly. Refer to Chapter 3, “Maintaining the Printer.”

Printer Operation Problems (continued)

Symptom	Possible Causes	Solution
Printer slows down.	The image bands or print speed is incorrectly set. The printer has aborted and reset the print speed and image bands.	Use PrintSet to change the image bands or print speed settings. Use PrintSet to change the image bands or print speed settings.
Labels stick to door or fail to strip.	The self-strip roller is dirty.	Clean the self-strip roller. See Chapter 3, “Maintaining the Printer.”
The Alert LED flashes and printing stops.	Printhead has overheated.	Leave printer alone until it has time to cool down. It will resume printing on its own.
Media fault.	The printhead is up. Sensor type set incorrectly. The media is incorrectly loaded.	Make sure the printhead is down. The head lift lever should be straight up and down. Press the Feed/Pause button to resume printing. Configure the printer for the correct sensor for the Print mode you are using. You can enable self-strip and other Print modes from PrintSet. Try reloading the media. For help, see “Loading Media Into the Printer” on page 18.
Test configuration label does not print.	The media is incorrectly loaded. The printer is configured for self-strip media. Media fault.	Try reloading the media. For help, see “Loading Media Into the Printer” on page 18. Set the printer to the default configuration using the DIP switches. For help, see “Plugging In the Printer” on page 3. Remove media from under the label taken sensor.
Printer is not communicating, not printing, or not printing properly.	Corrupt or incorrect information in printer memory.	Reset the memory to return the printer to its default configuration. For help, see “Resetting the Memory on Your Printer” on page 58. After you reset the memory, power off the printer and return the DIP switches to the required setting. For help, see “Configuring the Serial Port for Communications” on page 12.

Print Quality Problems

If your labels are not printing properly, check the following table to locate the symptom and correct the problem.

Print Quality Problems

Symptom	Possible Causes	Solution
Blotches printing on labels.	Dirty printhead.	Clean the printhead. For help, see “Cleaning the Printhead” on page 34.
	Dirty media path or rollers.	Clean the media path. For help, see “Cleaning the Media Guides and Media Path” on page 37.
	Poor quality label or ribbon stock.	Use only Intermec label and ribbon stock to ensure superior print quality and product performance.
Printing is too light or too dark.	Incorrect media sensitivity setting.	Change sensitivity setting to match the type of media you are using. For help, see “Setting the Media Sensitivity Number” on page 24. If you set the sensitivity setting correctly, try changing the dark adjust.
	Incorrect darkness adjust control setting.	Adjust the knob to achieve the best print quality. For help, see “Adjusting the Print Darkness” on page 49.
	Poor quality label or ribbon stock.	Use only Intermec label and ribbon stock to ensure superior print quality and product performance.
	Dirty printhead.	Clean the printhead. For help, see “Cleaning the Printhead” on page 34.
Printing not aligned on label.	Printer is misfeeding media.	Make sure you have correctly installed the media. For help, see “Loading Media Into the Printer” on page 18.
Labels are not stopping at the right point for removal.	Incorrect label rest point setting.	Adjust the label rest point. For help, see your PrintSet online help or the <i>IPL Programming Reference Manual</i> .
	Incorrect label stock setting.	Set the printer to thermal transfer or direct thermal label stock. For help, see “Loading Media Into the Printer” on page 18.
Print quality is poor.	Incorrect media sensitivity setting.	Change sensitivity setting to match the type of media you are using. If you set the sensitivity setting incorrectly, try changing the print darkness. For help, see your PrintSet online help or the <i>IPL Programming Reference Manual</i> .
	Incorrect darkness control setting.	Adjust the darkness adjust control. For help, see “Adjusting the Print Darkness” on page 49.
	Print speed exceeds the capability of the media.	Lower your print speed or use Intermec media recommended for your print speed.

Print Quality Problems (continued)

Symptom	Possible Causes	Solution
Print quality is poor. (continued)	Printhead, platen roller, or label path are dirty.	Clean printhead, platen roller, and label path as described in Chapter 3, “Maintaining the Printer.”
	Uneven print contrast (density). The printhead pressure may be set incorrectly for the media width.	Adjust the bias adjust screw. See “Correcting Uneven Print Quality” on page 48.
	Poor quality label or ribbon stock.	Use only Intermec label and ribbon stock to ensure superior print quality and product performance.
	Ribbon wrinkling. The printhead pressure may be set incorrectly for the media width.	Check to make sure that you installed the ribbon correctly. For help, see “Loading Thermal Transfer Ribbon” on page 22. Adjust the bias adjust screw. See “Correcting Uneven Print Quality” on page 48.
	Ribbon installed upside down.	Install ribbon with shiny side facing the printhead. See “Loading Thermal Transfer Ribbon” on page 22.
	Direct thermal/thermal transfer switch set in the wrong position.	Set the switch for the type of media you are using. For help, see “Loading Media Into the Printer” on page 18.
	Media may be slipping against the platen roller causing the printing to compress.	Switch to approved media or clean the printhead and platen roller as described in Chapter 3, “Maintaining the Printer.”
The printer skips labels randomly or sends an intermittent error.	The label format extends beyond the label length.	Edit the format to ensure that the text fits on the label.
Continuous empty/pause fault light (yellow LED).	The label mark sensor is not in the correct position.	Properly position the label mark sensor. For help, see “Adjusting the Label Mark Sensor” on page 50.

Communication Problems

If your printer is not receiving downloaded data, try the solutions in the accompanying table.

Communication Problems

Symptom	Possible Causes	Solution
Printer does not communicate with the host.	Serial port is incorrectly configured.	Make sure the printer’s serial port settings match those of the host. To check the serial port settings, print a software configuration test label as described on page 25.
	Damaged or incorrect I/O cable.	Check the connections at both ends or replace the cable. See Appendix C for cable information.

Preventing Data Loss

Several problems can cause data loss or communication problems on the printer. Data loss can result in printing errors or missing field data.

Your printer is a serial ASCII device. It communicates with the host through an ASCII serial communication I/O port. Hardware handshaking involves the use of a hardware wire. Software handshaking involves a two-way datalink between the devices. The two devices communicate with each other without losing data through the use of handshaking. The printer sends both forms of handshaking simultaneously when the printer's input buffer is full. Any loss of data can cause printing errors.

Hardware handshaking uses pin 11 or pin 20 of the RS-232 interface to control data flow. When the printer is using Intermec Standard protocol, it holds pins 11 and 20 high when the printer is ready to receive data. The printer holds the pins low when the printer is in one of the following conditions:

- Buffer full
- Ribbon fault
- No label stock
- Label at strip bar

Your printer uses XON/XOFF protocol for software handshaking. When the input buffer is full, the printer transmits an XOFF character. The XOFF character alerts the host to the fact that the printer buffer is full and cannot receive any more data. When the printer is ready to receive more data, it sends the XON character.

The following procedure lists things to check to ensure that your printer and host system are communicating properly.

To check for communication problems

- 1 Check the cabling from the printer to the host system.
- 2 Check the interfacing of the devices that are communicating with the printer.
- 3 Check the printer for proper electrical operation of the I/O port.
- 4 Test to see that the host system is not overrunning the printer's input buffers.
- 5 Check to see that the data string being sent to the printer contains the correct information.



5 Optimizing Printer Performance

This chapter explains how to optimize and maintain print quality, use the printer memory more efficiently, and maximize throughput. This chapter covers these topics:

- Optimizing and maintaining print quality
- Correcting uneven print quality
- Adjusting the print darkness
- Adjusting the label mark sensor
- Using the printer memory efficiently
- Increasing throughput

Optimizing and Maintaining Print Quality

Intermec designed and configured your printer to provide the best possible print quality for both direct thermal and thermal transfer media. However, there are many factors that you need to take into account before you can achieve maximum print quality.

Correcting Uneven Print Quality

You may experience problems in print quality (ribbon wrinkling or light print on one side of your label) if the printhead is not making even contact with the label stock. This condition can happen with any size label stock, but is most common when using narrow label stock. You need a straight-slot screwdriver to turn the bias adjust screw.

To achieve the best print quality, adjust the bias adjust screw each time you use media of a different width.



Note: You must properly adjust the bias adjust screw to prevent premature printhead failure and excessive platen wear.

To adjust the bias adjust screw

- 1 Remove the media cover and locate the bias adjust screw.

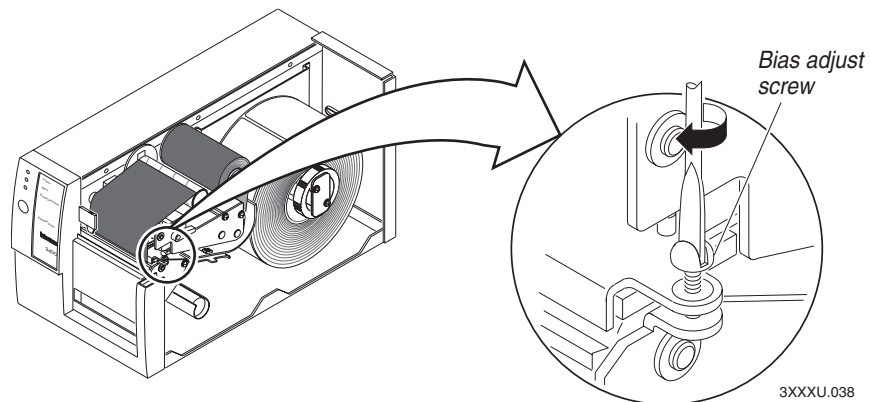

- 2 To compensate for uneven print quality, turn the bias adjust screw as shown. Adjusting the bias adjust screw causes the printhead to rest evenly on the drive roller and results in even print quality.

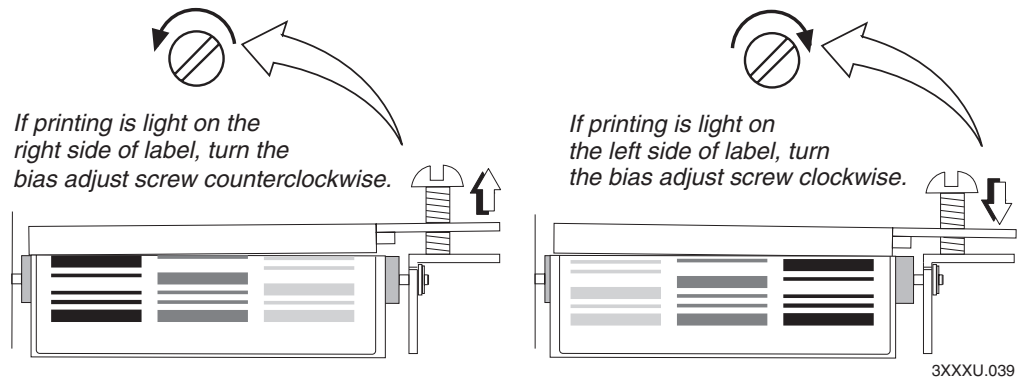

3 Replace the media cover.

Adjusting the Print Darkness

Use the darkness adjust control in combination with the PrintSet software configuration tool to fine-tune the darkness of print on your labels. The fine adjustments compensate for variations in the media (“lot to lot”), the printhead, or the printer. Set the darkness adjust control **after** you enter the media sensitivity number.

To adjust the print darkness

- 1 Locate the darkness adjust control on the back of the printer.
- 2 Use a small straight-slot screwdriver to adjust the print darkness. See the next illustration.
 - To increase the print darkness, turn the control clockwise.
 - To decrease the print darkness, turn the control counterclockwise.

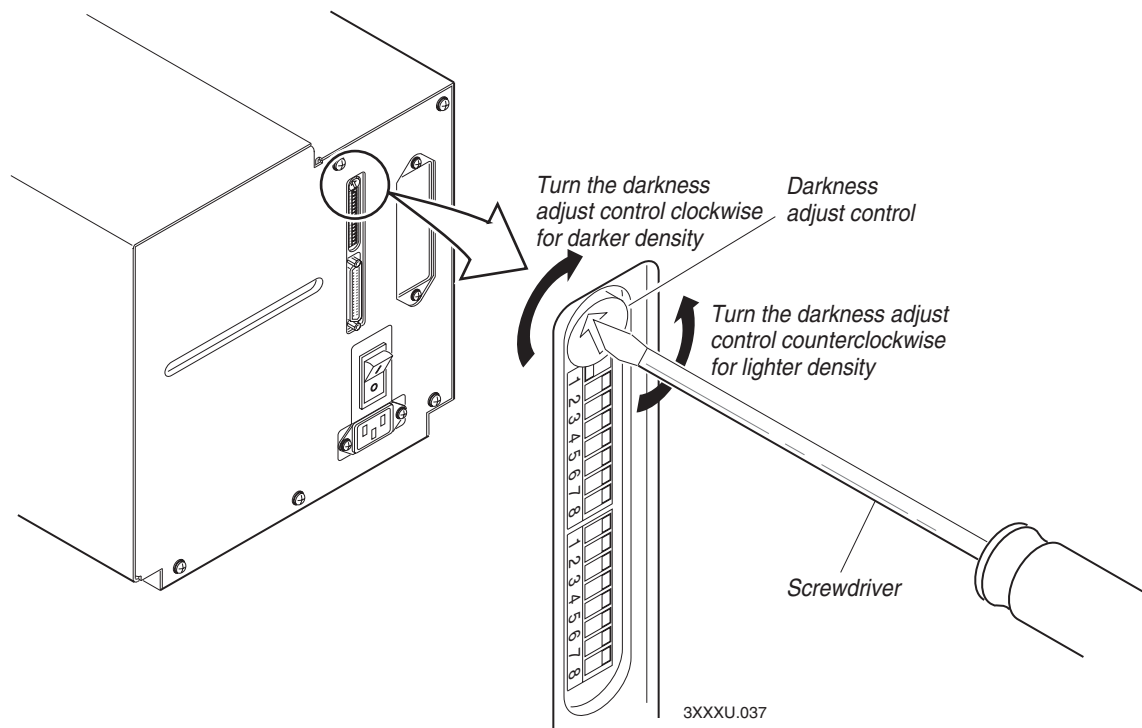

Adjusting the Label Mark Sensor

The label mark sensor detects the mark on the back of continuous media stock. The printer uses the output to determine the start of print. The label mark sensor is behind the platen roller and near the inboard edge of the printer.

To adjust the label mark sensor

- 1 Remove the media cover and locate the label mark sensor.
- 2 Use your index finger to slide the label mark sensor to the correct position for your media. You can position the label mark sensor anywhere from the inboard edge of the printer to the center of the paper path. See the next illustration.

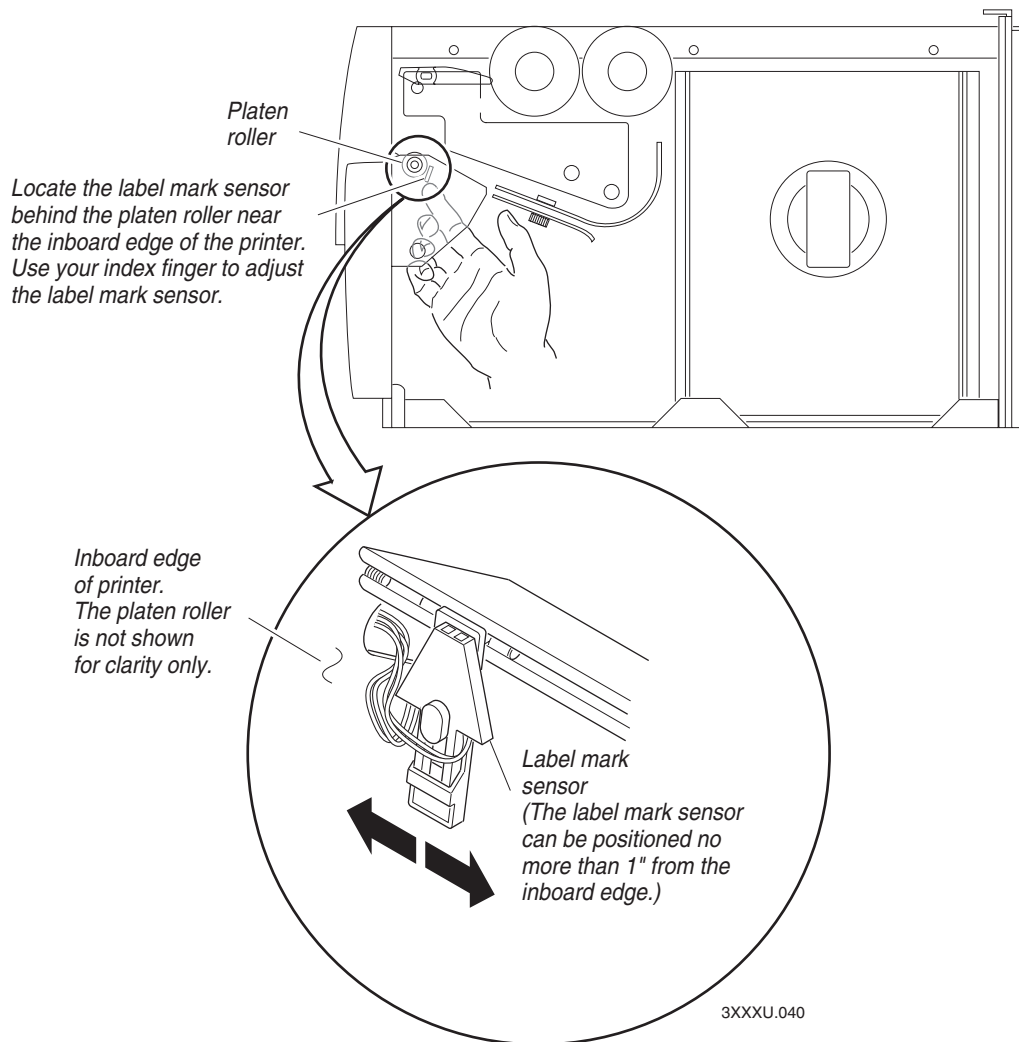

- 3 Enable mark printing with PrintSet, your third-party software, or IPL commands. For help, see PrintSet online help, your third-party documentation, or the *IPL Programming Reference Manual*.
- 4 Print a few labels or press Feed/Pause two times to make sure that the label mark sensor is detecting the black mark on the media.
- 5 Replace the media cover.

Using the Printer Memory Efficiently

To receive the best performance from your printer, you must understand how to use the printer memory. The following sections can help you determine the most efficient way to use your printer memory.

How Is the Printer Storage Memory Used?

There is enough storage memory in the printer to store several different label formats and still retain enough memory to store downloaded fonts, graphics, and data. Be careful of how you use your printer memory.

The printer uses flash memory for storing tables, pages, formats, fonts, and user-defined characters (UDCs). The 3400e printer has 128K of flash memory available for storage. If you require additional storage memory, you can purchase flash SIMM for the printer.

The printer supports these parameters independent of the amount of memory installed or allocated by the printer:

- Maximum number of formats: 99
(You can edit formats 1 to 99. You cannot edit default format 0.)
- Fields per format: 200
- Maximum data buffer size for a field: 3550
- Maximum number of UDCs: 100
- Maximum number of user-defined fonts: 16

Making the Most of Your Memory

There are limits to the number of formats, fonts, graphics, or pages that you can store in the printer. You can define up to 16 fonts, but there may not be enough room depending on the amount of memory being used for other purposes. The more formats, graphics, and fonts you store, the less memory is available.

When you run into a memory usage problem, use PrintSet to see how much memory remains available. You must upload the memory information from the printer first. Refer to the PrintSet online help for more information.

If you find that it is necessary to increase your available memory, you can do one of the following:

- Increase the amount of available memory by using the Memory Reset portion of the Test and Service menu. See “Resetting the Memory on Your Printer” on page 58 for more information.

- Delete any unneeded user-defined fonts, graphics, pages, or formats. For help, see the PrintSet software or the *IPL Programming Reference Manual*.
- Purchase additional memory. Please contact your Intermec representative for information on purchasing additional memory for the printer.

Increasing Throughput

To print labels as quickly as possible, you must adjust the print speed in conjunction with the number of image bands [one image band equals 2.54 centimeters (1 inch) of label]. The print speed and image band settings determine the rate at which the printer processes the images of your labels. This rate in turn affects the throughput of the entire printing process.

The printer begins imaging the label as soon as it receives the command to select a format. Since the printer starts imaging the label so early, the chance that the imaging process will be unable to keep up with the print speed decreases and throughput improves. However, if the number of image bands is too low, the imaging process is unable to keep up with the print speed. In this case, the printer stops printing and starts again at the lowest print speed with the maximum number of image bands. If the image band command is set too high, the printer spends more time than necessary imaging and slows down label production.

What Is an Image Band?

Image bands are a section of memory where a picture of a label format is drawn. This drawing process is known as imaging. Once the picture is imaged, the printer loads the picture from the image bands to the printhead for printing. Each image band is equal to 2.54 centimeters (1 inch) of length of the label format. The number of image bands you use may be less than the length of the label you are printing. The number of image bands (in inches) does not have to equal the length of the label since the printer recycles the image bands. Once the contents of an image band have been printed, it may be reused to image the next section of the label.

Keep in mind that the more complex the label, the longer it will take to image each section, thus requiring a slower print speed. To use a higher print speed, use more image bands to allow more of the imaging process to complete before printing begins.

How the Image Bands Command Works

The image bands command controls the amount of memory allotted to the imaging process. When you increase the image band adjustment to a higher number, you add more buffers to the imaging memory. By doing this, more of the label format is imaged before printing begins.

The minimum number of required image bands is dependent upon the print speed and the complexity of the label. Labels that contain numerous fields with different rotations, graphics, or combinations of these formatting options may require a higher number of image bands.

To set the number of image bands, use PrintSet or the IPL command. For help, see the PrintSet online help or the *IPL Programming Reference Manual*.

Optimizing Print Speed and Image Band Setting

The maximum number of image bands available for use is 20 bands. The minimum number of image bands available is 2.

To optimize the number of image bands for your print speed

1 Set the image band setting at the lowest number (2).

2 Print a label at the desired speed.

If the label prints, the image band setting is optimal. You do not need to perform any more adjustments.

If the number of image bands is too low, the printer aborts the label before printing is completed and attempts to reprint the label at the slowest speed (2 ips) with the highest number of image bands (20). You need to continue with Step 3.

3 Return to the original print speed and increase the original number of image bands one at a time.

Continue to increase the number of image bands until the printer prints a label correctly.

If the printer still aborts and reprints at the highest image band setting, you may be trying to optimize at a print speed that is too high for your label format. Try optimizing the number of image bands at a lower print speed or add an expansion DRAM SIMM.

To print very complex labels at high speeds, you must allocate enough image bands to completely image the label before printing. Allocate one band for each inch of label length. By doing this, you can print at any speed. However, there may be a considerable delay between labels.



6 Using Test and Service Mode

This chapter explains the different procedures you can perform while the printer is in Test and Service mode. Use Test and Service mode on the printer to print test labels, perform special procedures, and change select configuration commands. This chapter covers these topics:

- How to use Test and Service mode
- Printing test labels
- Using data line print to troubleshoot communications
- Resetting printer memory
- Setting configuration commands

Using Test and Service Mode Procedures

For all Test and Service mode tests, pressing the Feed/Pause button pauses the current test. Holding the Feed/Pause button aborts the current test and starts a new test.

To enter Test and Service mode

- 1 Record your current DIP switch settings for later reference.
- 2 Set all of the DIP switches to the off position.
Set all of the DIP switches to the communications settings of your host computer.
- 3 Turn the On/Off switch to the off position.
- 4 Press and hold the Feed/Pause button while turning the power on.
The printer prints out a hardware configuration label and then enters Data Line Print mode.
- 5 Set the DIP switches to the test or service function you wish to perform.
See the following illustration for a list of the DIP switch settings.
- 6 Hold the Feed/Pause button down. The test begins immediately.
- 7 If you want to perform another function, change the DIP switch settings and press the Feed/Pause button.
The function the printer is currently executing terminates, and the printer performs the new function.

The printer remains in Test and Service mode until you turn the power off and reset the DIP switches. The printer executes all functions as soon as you select them.

To exit Test and Service mode

- 1 Turn the printer power off.
- 2 Reset the DIP switches to their original settings.
- 3 Turn the printer power back on.

Use the information in the following illustration to set the DIP switches for the appropriate Test and Service mode function you want to perform.

Default settings are noted with an *

O = OFF
1 = ON

TESTS

OFF

ON

Top Bank

Bottom Bank

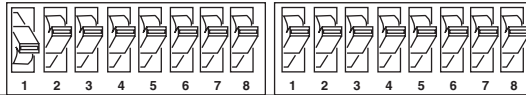

TESTS	1	2	3	4	5	6	7	8	1	2	3	4	5	6	7	8
Test Prints	O	O	O													
Configurations				O	O	O										
Hardware*							O	O								Q
Software									1	O						Q
Test Labels				1	O	O										
Print Quality							O	O								Q
Pitch																Q
Page				O	1	O	O	O								
Single Page									N	N	N	N	N			Q
All Pages									1	1	1	1	1			Q
Format				1	1	O	O	O								
Single Format									N	N	N	N	N			Q
All Formats									1	1	1	1	1			Q
UDC				O	O	1	O	O								
Single UDC									N	N	N	N	N	N	N	Q
All UDCs									1	1	1	1	1	1	1	Q
Font				1	O	1	O	O								
Single Font									N	N	N	N	N			
All Fonts									1	1	1	1	1			
Data Line Print				*1	O	O	O	O	O	O	O	O	O			
Selective Transfer				1	1	O										
Receiver							O	O	O							
Send Pages							1	O	O	S						
Single Page											1	S	S	S	D	D
All Pages												1	1	1	1	1
Send Format				O	1	O	S									
Single Format													1	S	S	S
All Formats														1	1	1
Send UDC				1	1	O	S									
Single UDC																1
All UDCs																1
Send Font				O	O	1	S									
Single Font																1
All Fonts																1
Send Configuration																
Send Tables																
Send All																
Memory Reset				O	O	1										
Page/Format							O	O	O							
UDC/Font							1	O	O							
Configuration							O	1	O							
Tables							1	1	O							
All							1	1	1							

Q: OFF = Batch of 1. ON = Batch of 100.
N: Page/Format/UDC/Font number. Least significant bit first.
S: Source Page/Format/UDC/Font number. Least significant bit first.
D: Destination Page/Format/UDC/Font number. Least significant bit first.

3XXXU.041

Test and Service mode DIP switch settings: This illustration shows DIP switch settings for Test and Service mode functions.

Printing Test Labels

The printer can print a variety of test print labels that provide you with information about the printer configuration and the quality of the printing.

To print a test label

- 1 Turn the On/Off switch to the off position.
- 2 Press and hold the Feed/Pause button while turning on the printer.
The printer prints a hardware configuration label and then enters Data Line Print mode.
- 3 Set the DIP switches to print the test label of your choice: software, print quality, or pitch. Refer to the Test and Service Mode DIP Switch Settings illustration on page 57 for the correct settings.
- 4 Hold the Feed/Pause button down until the printer starts printing.
The printer begins printing out the test label immediately.
- 5 Exit Test and Service mode by turning the printer off and returning all DIP switches to their original settings.

Using Data Line Print

Use Data Line Print mode to troubleshoot communication between the printer and the host and to test the operation of the printer. When the printer is in Data Line Print mode, it prints out all downloaded data with the hexadecimal equivalent directly underneath it. Hold the Feed/Pause button down to momentarily suspend the test. Press the Feed/Pause button longer to transmit the firmware program and version number to the host.

To enter Data Line Print mode

- 1 Turn the On/Off switch to the off position.
- 2 Press down and hold the Feed/Pause button while turning on the printer.

The hardware configuration test label prints out. You are now in Data Line Print mode.

Resetting the Memory on Your Printer

Use memory reset if you want to return your printer to its default configuration or if you need to increase the amount of memory available in your printer. You can also use memory reset to clear pages and formats, user-defined characters and fonts, configurations, tables, or all of these parameters.

To use memory reset

- 1 Turn the printer off.
- 2 Press and hold the Feed/Pause button while turning on the printer. The printer prints a hardware configuration test label.
- 3 Set the DIP switches to reset a portion or all of the memory by using the Test and Service Mode DIP Switch Settings illustration on page 57.
- 4 Hold the Feed/Pause button down for 1 second. The printer resets a portion or all of its memory.

Setting Configuration Commands in Test and Service Mode

Test and Service mode also provides you with an alternative to using PrintSet or sending configuration commands down from the host. You can change these configuration commands by setting the Test and Service mode DIP switches:

- Label rest point
- 86XX emulation
- X forms adjust
- Y forms adjust

	Top Bank								Bottom Bank							
	1	2	3	4	5	6	7	8	1	2	3	4	5	6	7	8
O = OFF																
1 = ON																
Label Rest Point	O	1	1													
Adjust Forward				O					N	N	N	N	N			
Adjust Backward				1					N	N	N	N	N			
86XX Emulation	1	O	1													
Advance Mode					O	O										
10 Mil					1	O										
15 Mil					1	1										
X Forms Adjust	1	1	1	1												
Adjust Forward						O			N	N	N	N	N			
Adjust Backward						1			N	N	N	N	N			
Y Forms Adjust	1	1	1	O					N	N	N	N	N			

N: Number. Least significant bit first.

3XXXU.046

Configuration DIP switch settings: This illustration shows the Test and Service mode DIP switch settings for changing the configuration commands.

Setting the Number of Dot Increments

You can move the label rest point and X forms adjust configuration commands forward or backward by setting the printer DIP switches. Use the top bank of DIP switches to determine whether the movement is forward or backward. Use the bottom bank of DIP switches to set the number of dot increments for label rest point, X forms adjust, and Y forms adjust. The printer moves in 5 mil increments or 0.005 inch per dot.

Bottom Bank

0 = OFF
1 = ON

OFF

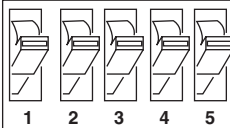

ON

# of dot increments	1	2	3	4	5
1	1	0	0	0	0
2	0	1	0	0	0
3	1	1	0	0	0
4	0	0	1	0	0
5	1	0	1	0	0
6	0	1	1	0	0
7	1	1	1	0	0
8	0	0	0	1	0
9	1	0	0	1	0
10	0	1	0	1	0
11	1	1	0	1	0
12	0	0	1	1	0
13	1	0	1	1	0
14	0	1	1	1	0
15	1	1	1	1	0
16	0	0	0	0	1
17	1	0	0	0	1
18	0	1	0	0	1
19	1	1	0	0	1
20	0	0	1	0	1
21	1	0	1	0	1
22	0	1	1	0	1
23	1	1	1	0	1
24	0	0	0	1	1
25	1	0	0	1	1
26	0	1	0	1	1
27	1	1	0	1	1
28	0	0	1	1	1
29	1	0	1	1	1
30	0	1	1	1	1

3XXXU.047

Dot increments DIP switch settings: This illustration shows the dot increment settings for the bottom bank of switches. See the previous illustration, Configuration DIP switch settings, for the top bank DIP switch settings.

To set the number of dot increments

- 1 In the top bank, turn the appropriate switches on or off for forward or backward movement. See the Configuration DIP Switch Settings illustration on page 59 for the appropriate DIP switch settings.
- 2 Go to the Dot Increments DIP Switch Settings illustration above and scan down the # of Dot Increments column until you reach the number of dot increments you want to adjust the command forward or backward.

- 3 In the bottom bank turn on the switches that have a 1 in their column. Turn off all other switches.
- 4 Press the Feed/Pause button and the printer prints the software configuration label and stops at the new location.

For example, you print a label and discover that it does not extend far enough from the tear bar. You need to move the label rest point forward 10 dot increments (0.05 inch) so that the printer feeds more label out when it is done printing. Find 10 in the # of Dot Increments column. It shows a 1 in the columns of DIP switches 2 and 4, and a 0 in the columns of 1, 3, and 5. The 1 tells you to turn the switch on. The 0 tells you to turn the switch off. Turn on switches 2 and 4. Turn off all other switches.

Adjusting the Label Rest Point

The label rest point configuration command adjusts the point at which the printer presents each label for removal. Use this command in conjunction with self-strip applications. The label rest point adjust range is from -30 dot increments (farthest back) to +30 dot increments (farthest forward).

Use a negative number if you want the printer to retract the label a number of dot increments after it prints the label. Use a positive number if you want the printer to feed the label a number of dot increments after it prints the label.

There are three ways to adjust the label rest point:

- You can use the Test and Service DIP switch bank. Follow the procedure below to use the DIP switch settings to adjust the label rest point.
- You can set it by using the PrintSet application software. See the Paper Handling portion of PrintSet for more information.
- You can use the IPL command. See the *IPL Programming Reference Manual* for more information.

To adjust the label rest point

- 1 Turn the On/Off switch to the off position.
- 2 Press and hold the Feed/Pause button while turning on the printer.
The printer prints the hardware configuration test label and then enters Data Line Print mode.
- 3 In the top bank of the Test and Service DIP switches, turn off switch 1 and turn on switches 2 and 3. See the next illustration.

To adjust the label rest point forward (feed more label), turn off DIP switch 4.

To adjust the label rest point backward (retract label), turn on DIP switch 4.

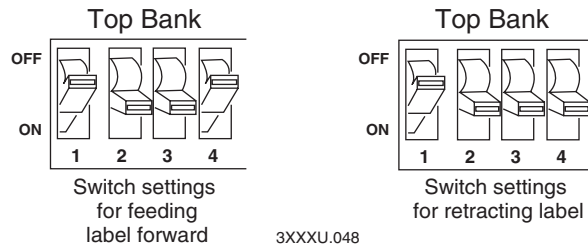

- 4 In the bottom bank of the Test and Service DIP switches, turn on or off the appropriate DIP switches. See the Dot Increments DIP Switch Settings illustration on page 60.
- 5 Press the Feed/Pause button.

The printer prints the software configuration label and stops at the new location.
- 6 Verify that the label rest point number on the software configuration label matches the number you set in Step 4.
- 7 Try printing again to see if you need to readjust the DIP switches in the bottom bank.
- 8 If you need to readjust the DIP switches in the Bottom Bank, repeat Steps 4 through 7. If not, exit Test and Service mode by turning off the printer and returning all DIP switches to their original settings.
- 9 Turn the On/Off switch to the off position.

Setting Emulation Mode

If you are replacing an Intermec 8636 or 8646 printer with a 3400e printer, you can keep your existing network, hardware, software, and label formats by using Emulation mode. The labels produced on your new printer will look like the ones that your old 86XX printer printed.

There are three ways to set the printer to Emulation mode:

- Use the DIP switches in the Test and Service DIP switch bank. For help, see the following procedure.
- Use PrintSet to select either 100 dpi (10 mil) or 66 dpi (15 mil) mode. For help, see the PrintSet online help.
- Use the IPL command set to select Emulation mode. For help, see the *IPL Programming Reference Manual*.

To set the printer to Emulation mode using DIP switches

- 1 Upload label formats, fonts, and graphics from the 8636 or 8646 printer to the host computer.
- 2 Turn the On/Off switch to the off position.
- 3 Disconnect the 86XX printer and install your printer. See Chapter 1 for information on installing your printer.

- 4 Press and hold the Feed/Pause button while turning on the printer. The printer prints the hardware configuration label.
- 5 In the top bank of the Test and Service DIP switches, turn on switches 1 and 3 and turn off switch 2.
- 6 Use the table below to help you choose the appropriate DIP switch settings:

Setting	Description
Emulation 10 mil	The printer emulates an 8636 or 8646 printer printing multiples of 10 mil (0.01 inch) drag and 10 mil (0.01 inch) picket bar codes.
Emulation 15 mil	The printer emulates an 8636 or 8646 printer printing multiples of 10 mil (0.01 inch) drag and 15 mil (0.015 inch) picket bar codes.
Advanced 5 mil (default)	The printer uses the 3400 command set and prints in multiples of 5 mil (0.005 inch) drag and 5 mil (0.005 inch) picket bar codes.

- 7 To enable 10 mil emulation, turn on DIP switch 4 and turn off DIP switch 5.

To enable 15 mil emulation, turn on DIP switches 4 and 5.

To enable 5 mil Advanced mode, turn off DIP switches 4 and 5.

- 8 Press the Feed/Pause button.

The printer prints out the software configuration label. Verify that the label states the correct mode.

- 9 Turn the printer off and then on.

- 10 Download the 86XX formats, fonts, and graphics from the host to the printer.

Using Forms Adjust

If your label prints too close to one edge, you can reposition it by using the X Forms Adjust and Y Forms Adjust features. The X forms adjust controls the position of the printing area along the length of the label. The Y forms adjust controls the position of the printing area along the width of the label.

The following illustration shows the default X and Y origins.

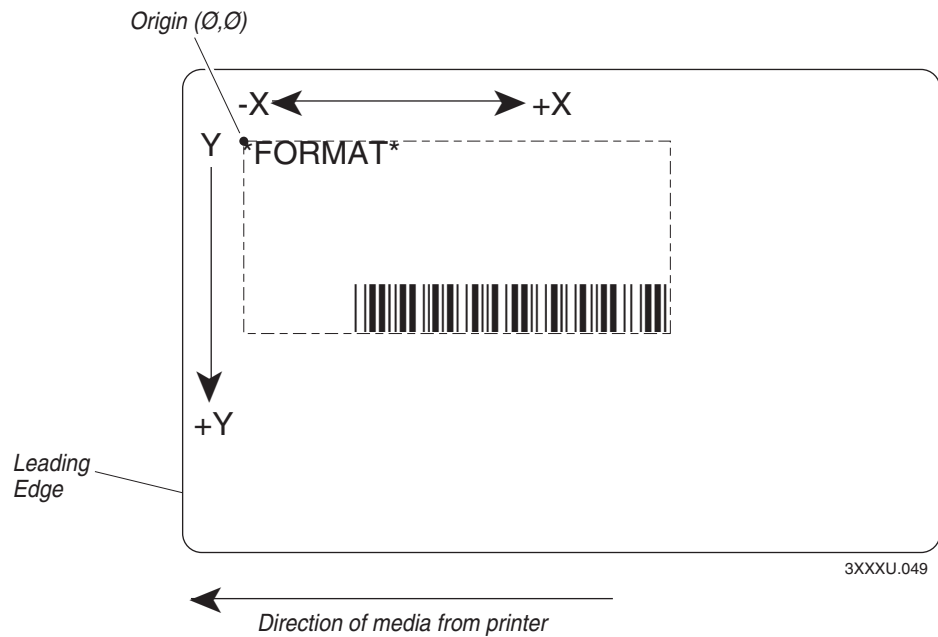

Default X and Y origins: This illustration shows the default X and Y origins. You can control the default X origin (top of form) with *PrintSet* or with the *Test and Service DIP* switches. You can control the default Y origin with the *DIP* switches only.

The default X origin is .25 centimeters (0.10 inch) (20 dot increments) from the edge of the label. You can move the X origin forward or back 30 dot increments. The default Y origin is .13 centimeters (0.05 inch) (10 dot increments) from the leading edge of the label. Each dot increment is 5 mil (0.005 inch).

X Forms Adjust

When you move the X origin forward, the printer moves the top of form away from the edge before printing the label information. When you move the X origin backward, the printer moves the top of form closer to the edge before printing the label information.

To set the X forms adjust

- 1 Turn the On/Off switch to the off position.
- 2 Press and hold the Feed/Pause button while turning on the printer.

The printer prints out the hardware configuration label and then enters Data Line Print mode.

- 3 In the top bank of the Test and Service DIP switches, turn on switches 1, 2, 3, and 4. See the next illustration.

To move the X origin forward, turn off switch 5.

To move the X origin backward, turn on switch 5.

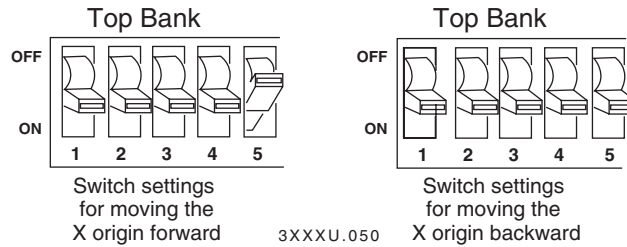

- 4 In the bottom bank of the Test and Service DIP switches, turn on or off the appropriate DIP switches. See the Dot Increments DIP Switch Settings illustration on page 60 to see how to set the X forms adjust forward or backward a given number of increments.
- 5 Press the Feed/Pause button.
The printer prints out the software configuration label using the new X forms adjust setting.
- 6 Verify the X forms adjust number on the software configuration label matches the number you set in Step 4.

Y Forms Adjust

Use the Y Forms Adjust feature to control the position of the image in the direction parallel to the printhead. See the Dot Increments DIP Switch Settings illustration on page 60 for information on how to move the image forward a number of dot increments. If your label is too close to one edge of the printhead, you can adjust it using this feature.

To set the Y forms adjust

- 1 Turn the On/Off switch to the off position.
- 2 Press and hold the Feed/Pause button while turning on the printer.
The printer prints out the hardware configuration label and then enters Data Line Print mode.
- 3 In the top bank of the Test and Service DIP switches, turn on switches 1, 2, and 3.
- 4 In the bottom bank of the Test and Service DIP switches, turn on or off the appropriate DIP switches. See the Dot Increments DIP Switch Settings illustration on page 60 to see how to set the X forms adjust forward or backward a given number of increments.
- 5 Press the Feed/Pause button. The printer prints out the software configuration label using the new Y forms adjust setting.
- 6 Verify the Y forms adjust number on the software configuration label matches the number you set in Step 4.



A Specifications

This chapter contains the following reference information:

- Specifications
- Printer options
- Bar code symbologies supported

Printer Specifications

This section describes the specifications of the 3400e printer.

Dimensions (no options installed)

Height	27.9 cm (11 in)
Width	26.7 cm (10.5 in)
Length	43.2 cm (17 in)
Weight	15.8 kg (35 lbs)

Electrical Requirements

Input Voltage	100, 120, or 230 VAC \pm 10%
Frequency	47-63 Hz

Environment

Operating	10°C to 40°C (50°F to 104°F)
Humidity	10% to 90% non-condensing

Character Sets

US ASCII	Norwegian/Danish
UK ASCII	Swedish/Finnish
German	Italian
French	Spanish
Swiss	

Communications

- Asynchronous RS-232C, RS-422, RS-485 interfaces
- Serial ASCII code
- Hardware (Ready/Busy) Flow Control
- XON/XOFF Protocol
- Intermec Standard Block Protocol
- Polling Mode D Protocol
- Multi-Drop Protocol
- Baud Rates: 1,200, 2,400, 4,800, 9,600, 19,200, 38,400, 57,00, 115,200

Fonts and Graphics

There are 21 resident bitmap fonts (including OCR A and B) and three outline fonts available on the e series printers. You can use font ID 3 through 6 and 8 through 19 to download user-defined fonts.

Maximum UDF	102 mm square (4 in square)
Maximum UDC	102 mm square (4 in square)

Media

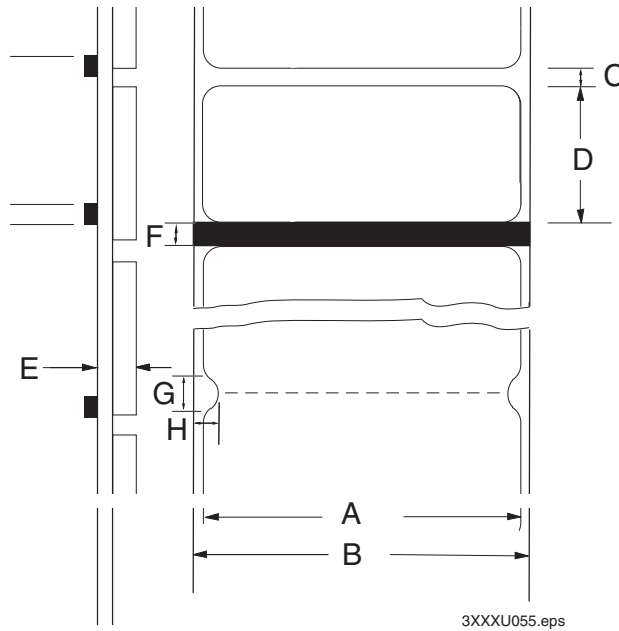

Media dimensions: This illustration shows how to measure the media dimensions. See the next table, *Minimum and Maximum Media Dimensions*, for specific media dimensions.

Minimum and Maximum Media Dimensions

Letter	Description	Minimum	Maximum
A	Label width	16.5 mm (0.65 in)	111.8 mm (4.4 in)
B	Backing width (or tag width)	19.1 mm (0.75 in)	114.3 mm (4.5 in)
C	Gap between labels	2.54 mm (0.10 in)	25.4 mm (1.0 in)
D	Label length - self-strip media	25.4 mm (1.0 in)	609.6 mm (24 in)
	Label length - butt cut media	12.7 mm (0.5 in)	609.6 mm (24 in)
E	Media thickness (including backing)	0.08 mm (0.0031 in)	0.30 mm (0.012 in)
F	Reflective sensor mark length	2.54 mm (0.10 in)	12.7 mm (0.5 in)
G	Notch length	2.54 mm (0.10 in)	3.18 mm (0.125 in)
H	Notch height (depth)	6.4 mm (0.25 in)	12.7 mm (0.5 in)
	Roll diameter	N/A	213 mm (8.38 in)

Printhead

200 dpi

Printed dot size	0.127 mm (0.00492 inch square)
Width	104 mm (4.1 inches square)
Resolution	8 dots per mm (203 dots per inch)
Number of elements	832 per printhead
“X” dimensions	10 mil to 50 mil (0.25 mm to 1.27 mm); 5 mil (0.13 mm) in drag mode only (specified media only)

400 dpi

Printed dot size	0.065 mm (0.0025 in square)
Width	112 mm maximum (4.4 in)
Resolution	16 dots per mm (406 dots per inch)
Number of elements	1,792 per printhead
“X” dimensions	5 mil to 50 mil (0.127 mm to 1.27 mm); 2.5 mil (0.06 mm) in drag mode only (specified media only)

Printing Method

The 3400e printer is capable of direct thermal (DT) printing or thermal transfer (TTR) printing using thermal transfer ribbon.

Printing Speed

Maximum	152.4 mm (8 inches) per second
Minimum	50.8 mm (2 inches) per second

You can change the print speed in 1 ips increments only: 2, 3, 4, 5, 6, 7, or 8.

Ribbon

Roll	152 m (6,000 linear in)
Widths	51 mm (2.0 in) 76 mm (3.0 in) 104 mm (4.1 in)
Diameter	57 mm (2.25 in maximum)

Self-Strip (optional)

Self-strip printing is an option that you order with your printer. The self-strip rewriter hub can take up the backing of an entire 15,240-centimeter (6,000-inch) roll of media.

Peel Release 10-50 grams

Printer Options

This section contains a list of the options you can use with the printer along with a brief description. Consult your Intermec representative to order any option.

Communication Interface

EasyLAN 10i Interface

This option lets you connect your printer to a 10BaseT Ethernet network. Various network printing protocols are available. For more information, see your EasyLAN™ 10i documentation.

EasyLAN 10i2 Adapter

The external EasyLAN 10i2 Ethernet adapter (P/N 072885) and the internal EasyLAN 10i2 Ethernet adapter (P/N 072884) allow you to share your available printer resources with everyone on your Ethernet network. With the EasyLAN 10i2 adapter installed, the parallel port on the printer is not available for use. For more information, see the EasyLAN 10i2 documentation.

EasyLAN Wireless Option

The EasyLAN Wireless is an 802.11b radio option that lets the printer communicate wirelessly with a PC that contains an 802.11b radio card (ad-hoc network) or it can communicate with other devices via an access point (infrastructure network) in your data collection network. For more information, see the EasyLAN Wireless documentation.

Twinax Interface

This option lets you connect your printer to an IBM twinaxial cable system with a twinax interface so your printer emulates an IBM 5256 Model 1 printer and can operate with an IBM System/34, System/36, System/38, or AS/400 host computer.

Coax Interface

The coax interface adapter allows the printer to emulate an IBM 3287 printer by connecting the printer to IBM 3270 Type A coaxial cable computer systems operating in the VTAM (CICS/IMS/TSO) or 8100 (DPPX) environments. With the coaxial adapter you can connect the printer to an IBM 3174/76/99 system controller/multiplexer.

Finishers

Cutter

Use the cutter option to cut continuous media into individual labels ready for use. This 3400 option works best for individual random lengths or short batches of different label lengths.

Batch Takeup

This device automatically spools labels as they are printed. This attachment is limited to small batches with maximum outer diameter (OD) of 12.7 centimeters (5 inches).

Self-Strip Printing

Use self-strip printing in applications where you want to apply labels to a surface immediately. After printing a label, the printer prints out the label with the backing removed. This option must be ordered when you order your printer.

Kanji/Katakana

This option allows the printer to print Japanese characters in two Kanji fonts and three Katakana fonts. This option also provides increased storage capacity.

Memory Expansion

You can install a flash SIMM module into the SIMM socket on the main PCB to hold more fonts or bitmap graphics. You can also install a DRAM SIMM to increase the image buffering capabilities of the printer. You can purchase either module in 8 or 16 MB sizes only.

Parallel Interface Pin Descriptions

The following table lists the pin descriptions for the printer's parallel interface connector.

Parallel Interface Pin Descriptions

Signal	Pin	Return	Direction	Description
DATASB	1	19	IN	Negative pulse. Latches DB0-7 on the rising edge. Eight bits in parallel provide data input. High is logical 1 and LOW is logical 0.
DB0	2	20	IN	
DB1	3	21	IN	
DB2	4	22	IN	
DB3	5	23	IN	

Parallel Interface Pin Descriptions (continued)

Signal	Pin	Return	Direction	Description
DB4	6	24	IN	
DB5	7	25	IN	
DB6	8	26	IN	
DB7	9	27	IN	
ACK	10	28	OUT	Negative pulse. Data has been received.
BUSY	11	29	OUT	If HIGH, printer cannot receive data.
PE	12	30	OUT	If HIGH, out of ribbon or media.
SELECT	13	-	OUT	Pulled to +5V. Printer is on.
CHASSIS GND	17	-	-	Printer's chassis gnd isolated from logic gnd.
INIT	31	16	IN	Clears I/OINT0 latch.
FAULT	32	33	OUT	See printer display.

Bar Code Symbolologies Supported

The e series printers support the following bar code symbolologies.

Supported Bar Code Symbolologies

Symbology	Description
Codabar	Originally developed in 1972, Codabar is a numeric symbology most commonly used in libraries, blood banks, and air parcel express applications.
Code 2 of 5	Code 2 of 5 is a straightforward numeric symbology developed in the late 1960s. It has been used for warehouse sorting systems, photofinishing envelope identification, and for tracking sequentially numbered airline tickets. All information is contained in the width of the bars; the spaces do not contain information.
Code 11	Code 11 was developed in early 1977 to satisfy requirements for a very high density, discrete numeric bar code. The most extensive application of Code 11 has been for labeling telecommunications equipment.
Code 39	Code 39 is the first alphanumeric symbology ever developed and is the standard non-retail bar code. It is a discrete, self-checking symbology of variable length and is used mostly by the automobile and medical industries.
Code 93	Introduced in 1983, Code 93 was specially designed to complement Code 39. With the correct reading equipment, the two alphanumeric codes may be interchanged throughout a system without making any changes to software.
Code 128	Code 128 was introduced in 1981 as a very high density, alphanumeric symbology. It is a variable length, continuous code that employs multiple element widths.

Supported Bar Code Symbologies (continued)

Symbology	Description
EAN	The European Article Numbering system (abbreviated as EAN) is a numeric superset of UPC. EAN has both a version that uses 8 digits and a version that uses 13 digits. The version with 13 digits encodes the same number of bars as 12 digit UPC Version A, but the 13th digit is encoded into a parity pattern at the left of the center guard bar.
Interleaved 2 of 5	Interleaved 2 of 5 is a high density, self-checking, continuous numeric symbology, which has mainly been used in the distribution industry. Interleaved 2 of 5 actually encodes two digits, one in the bars and one in the spaces.
POSTNET	The Postal Numeric Encoding Technique (POSTNET) uses binary digits, represented as full bars and half bars, to provide a numeric bar code symbology that is easily read and decoded by optical reading systems. POSTNET provides both error detection and correction capabilities.
HIBC 128	See the <i>IPL Programming Reference Manual</i> for a complete list.
UPC	Universal Product Code (UPC) is a subset of EAN. It is a fixed length, numeric, continuous symbology employing four element widths. Two common types of UPC are Version A, which encodes 12 digits, and Version E, which encodes 6 digits. UPC has been used in the supermarket industry since 1973. UPC supplemental code is intended for only periodical issue numbers.

2D Symbologies

2D symbologies provide a more efficient way of encoding data than standard bar code symbologies. 2D symbologies use two dimensions to hold data instead of one, allowing much more information to be stored in a smaller amount of space. Your printer provides the capability for printing both stacked and matrix 2D symbologies.

2D Stacked Symbologies

2D stacked symbologies consist of short linear segments stacked on top of each other. In addition to being able to condense a large amount of information into the stacked format, PDF417 provides an extensive error detection and correction option. Up to 510 characters can be recovered if they are lost due to an error in scanning or if the label is damaged. 2D stacked symbologies can be scanned with a laser scanner or imaging device that features 2D code scanning capability.

Supported 2D Stacked Symbologies

Symbology	Description
Code 16K	Introduced in 1988, Code 16K is an alphanumeric symbology similar to Code 49 in that it employs multiple rows (from 2 to 16). Each row is fixed length and uses a mirror image of the Code 128 coding patterns.

Supported 2D Stacked Symbologies (continued)

Symbology	Description
Code 49	Code 49 is an alphanumeric symbology developed in 1987 as a means of labeling very small objects. A Code 49 bar code contains from two to eight adjacent bars, each separated by a one-module separator bar.
PDF417	PDF417 is a stacked 2D symbology that provides the ability to scan across rows of code. Each row consists of start/stop characters, row identifiers, and symbol characters (called “codewords”). Each codeword consists of four bars and four spaces and contain the actual data. In addition to being able to condense a large amount of information into the stacked format, PDF417 provides an extensive error detection and correction option. Up to 510 characters can be recovered if they are lost due to an error in scanning or if the label is damaged. PDF417 codes can be scanned with a laser scanner or imaging device that features 2D code scanning capability.

2D Matrix Symbologies

2D matrix symbologies, such as Maxicode, use both the horizontal and vertical axes to encode data even more efficiently than stacked symbologies. 2D matrix codes are created as a matrix of square elements, with each element being either white or black to encode data in a binary code. Extensive error detection and correction codes are appended to 2D matrix symbologies, often automatically.

2D matrix symbologies generally cannot be read with a laser scanner. Instead, they are read by a digital imager that captures the entire symbol at once instead of scanning each component individually. Since the components of 2D matrix symbologies are decoded after the image is captured, they permit very fast data collection.

Supported 2D Matrix Symbologies

Symbology	Description
Data Matrix	Data Matrix is a 2D matrix symbology that is made up of square modules arranged within a perimeter finder pattern. The finder pattern is a perimeter to the data region and is one module wide. Two adjacent sides are solid dark lines. These lines are used to define physical size, orientation, and symbol distortion.
Maxicode	Maxicode is a fixed-size symbology that is made up of offset rows of hexagonal elements arranged around a bull’s eye finder pattern. Each hexagon represents one bit of information and is either black or white depending on the state of the encoded data bit. United Parcel Service (UPS) Research and Development developed Maxicode for the specific purpose of encoding information about a parcel. This symbology only encodes very specific data that is divided into the following fields: a 5-digit zip code, a 4-digit zip code extension, a 3-digit country code, a 3-digit class of service, and a string of uppercase letters, numbers, or limited punctuation marks.

Supported 2D Matrix Symbologies (continued)

Symbology	Description
QR Code	QR (Quick Response) Code is a matrix 2D symbology that encodes data into patterns consisting of black and white dots or modules. A three-position detection pattern enables omni-directional reading and ultra high-speed reading. QR Code can handle a wide range of data, including numerical, alphabetical, Kanji, Hiragana, Katakana, graphics, and control codes. A built-in error correction function enables the QR Code to repair errors in the code.

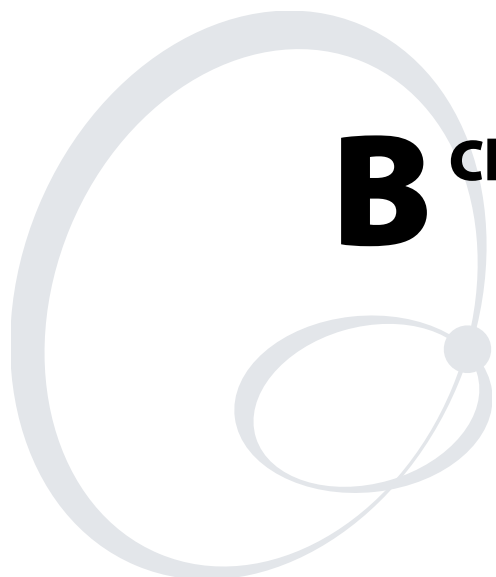

B Character Sets

This chapter contains tables for the character sets that the 3400e printer supports. To select a character set, use PrintSet, your third-party software application, or the IPL command set. This chapter contains these character sets:

- International character sets
- Extended character sets

International Character Sets

The following tables show which hex codes to download for international characters not available in the U.S. character set. To use the tables, find the hex code for the U.S. character that corresponds with the character in your language.

Advanced Character Table

If you are running your printer in Advanced mode (you are not using 86XX Emulation), use this table to find the right hex codes for the international character sets.

Advanced Mode Hex Codes

	23	24	40	5B	5C	5D	5E	60	7B	7C	7D	7E
U.S. ASCII	#	\$	@	[\]	^	`	{		}	~
U.K. ASCII	£	\$	@	[\]	^	`	{		}	—
Germany	#	\$	§	Ä	Ö	Ü	^	`	ä	ö	ü	ß
France	£	\$	à	°	ç	§	^	`	é	ù	è	..
Norway/Denmark	#	\$	@	Æ	Ø	Å	^	`	æ	ø	å	—
Sweden/Finland	#	□	É	Ä	Ö	Å	Ü	é	ä	ö	å	ü
Spain	£	\$	§	ı	Ñ	¿	^	`	°	ñ	ç	~
Switzerland	#	\$	à	°	ç	é	^	ù	ä	ö	ü	è
Italy	£	\$	§	°	ç	é	^	ù	à	ò	è	ì

Emulation Mode Character Table

This table shows the hex codes for the character sets that print if your printer is running under Emulation mode.

Emulation Mode Hex Codes

	23	24	40	5B	5C	5D	5E	60	7B	7C	7D	7E
U.S. ASCII	#	\$	@	[\]	^	`	{		}	~
U.K. ASCII	£	\$	@	[\]	^	`	{		}	~
Germany	#	\$	§	Ä	Ö	Ü	^	`	ä	ö	ü	ß
France	£	\$	à	°	ç	§	^	`	é	ù	è	..
Norway/Denmark	#	\$	@	Æ	Ø	Å	^	`	æ	ø	å	~
Sweden/Finland	#	□	É	Ä	Ö	Å	Ü	é	ä	ö	å	ü
Spain	P _t	\$	@	ı	Ñ	¿	^	`	..	ñ	ç	~
Switzerland	#	\$	à	°	ç	é	^	ù	ä	ö	ü	è
Italy	#	\$	§	°	ç	é	^	ù	à	ò	è	ì

IBM Translation Character Table

If you are running your printer with IBM Translation enabled, use this table to find the right hex codes for the international character sets.

IBM Translation Hex Codes

	21	23	24	40	5B	5C	5D	5E	60	7B	7C	7D	7E
U.S. ASCII		#	\$	@	¢	\	!	¬	`	{		}	~
U.K. ASCII		#	£	@	\$	\	!	¬	`	{		}	—
Germany	!	#	\$	§	Ä	Ö	Ü	^	`	ä	ö	ü	ß
France	!	£	\$	à	°	ç	§	^	`	é	ù	è	¨
Norway/Denmark	!	Æ	Å	Ø	#	\	□	^	`	æ	ø	å	ü
Sweden/Finland	!	Ä	Å	Ö	§	É	□	^	é	ä	ö	å	ü
Spain		Ñ	P,	@	[\]	¬	`	{	ñ	}	¨
Switzerland	!	#	\$	à	°	ç	é	^	ù	ä	ö	ü	è
Italy	!	£	\$	§	°	ç	é	^	ù	à	ò	è	ì

Code Page 850 Character Table

00	☺	☹	♥	♦	♣	♠	●	◻	○	◼	♂	♀	♪	🎵	☀	
10	▶	◀	↕	!!	¶	§	—	↑	↓	→	←	L	↔	▲	▼	
20	!	"	#	\$	%	&	'	()	•	+	,	-	.	/	
30	0	1	2	3	4	5	6	7	8	9	:	;	<	=	>	?
40	@	A	B	C	D	E	F	G	H	I	J	K	L	M	N	O
50	P	Q	R	S	T	U	V	W	X	Y	Z	[\]	^	-
60	`	a	b	c	d	e	f	g	h	i	j	k	l	m	n	o
70	p	q	r	s	t	u	v	w	x	y	z	{		}	~	☐
80	Ç	ü	é	â	ä	à	å	ç	ê	ë	è	•	"	"	Ä	Å
90	É	æ	Æ	ô	ö	ò	û	ù	ÿ	Ö	Ü	ø	£	Ø	X	f
A0	á	í	ó	ú	ñ	Ñ	ã	õ	¿	®	¬	½	¼	i	«	»
B0	ı	ı	ı	ı	ı	Á	Â	À	©	¶		¶	¶	¢	¥	¬
C0	L	±	T	†	—	+	ã	Ã	℥	℞	±	¶	¶	=	¶	
D0	'	Ð	Ê	Ë	È	€	Í	Î	Ï	Ɔ	Ɔ	■	■	ı	ı	■
E0	Ó	β	Ô	Ò	õ	Õ	μ	þ	Ɔ	Ú	Û	Ù	ý	Ý	-	'
F0	-	±	=	¾	¶	§	÷	•	◦	••	•	1	3	2	■	FF

44XXU068.eps

Extended Character Sets

Each internal font in the printer has a different character set associated with it as shown in the following tables. The hex codes accompany each character.

Characters in Fonts

- c0 7 x 9 Standard
- c1 7 x 11 OCR
- c2 10 x 14 Standard
- c7 5 x 7 Standard

ML	SH	SH	EX	ET	EQ	PK	BL	BS	HT	LF	UT	FF	CR	SD	SI
00	01	02	03	04	05	06	07	08	09	0A	0B	0C	0D	0E	0F
DL	D1	D2	D3	D4	NK	SN	EB	CN	EM	SB	EC	FS	GS	KS	US
10	11	12	13	14	15	16	17	18	19	1A	1B	1C	1D	1E	1F
	!	"	#	\$	%	&	'	()	*	+	,	-	.	/
20	21	22	23	24	25	26	27	28	29	2A	2B	2C	2D	2E	2F
Ø	1	2	3	4	5	6	7	8	9	:	;	<	=	>	?
30	31	32	33	34	35	36	37	38	39	3A	3B	3C	3D	3E	3F
@	A	B	C	D	E	F	G	H	I	J	K	L	M	N	O
40	41	42	43	44	45	46	47	48	49	4A	4B	4C	4D	4E	4F
P	Q	R	S	T	U	V	W	X	Y	Z	[\]	>	_
50	51	52	53	54	55	56	57	58	59	5A	5B	5C	5D	5E	5F
'	a	b	c	d	e	f	g	h	i	j	k	l	m	n	o
60	61	62	63	64	65	66	67	68	69	6A	6B	6C	6D	6E	6F
p	q	r	s	t	u	v	w	x	y	z	{		}	~	■
70	71	72	73	74	75	76	77	78	79	7A	7B	7C	7D	7E	7F
R	à	■	□	△	▽										
80	81	82	83	84	85	86	87	88	89	8A	8B	8C	8D	8E	8F
90	91	92	93	94	95	96	97	98	99	9A	9B	9C	9D	9E	9F
	i	ç	ï	ÿ	š	š	š	š	š	š	š	š	š	š	š
A0	A1	A2	A3	A4	A5	A6	A7	A8	A9	AA	AB	AC	AD	AE	AF
•															~
B0	B1	B2	B3	B4	B5	B6	B7	B8	B9	BA	BB	BC	BD	BE	BF
				ä	å	æ			é						
C0	C1	C2	C3	C4	C5	C6	C7	C8	C9	CA	CB	CC	CD	CE	CF
	z					ö		ø				ü			ß
D0	D1	D2	D3	D4	D5	D6	D7	D8	D9	DA	DB	DC	DD	DE	DF
•				•	•	•	•	•	•	•	•	•			
E0	E1	E2	E3	E4	E5	E6	E7	E8	E9	EA	EB	EC	ED	EE	EF
	z	ö			ö	ø	•	•	•	•	•	•			
F0	F1	F2	F3	F4	F5	F6	F7	F8	F9	FA	FB	FC	FD	FE	FF

44XXU069.eps

Characters in Fonts

- c20 8 point
- c21 12 point
- c22 20 point
- c25, c26, c28 outline fonts
- c30-c41 monospace fonts (6 point to 36 point)

00	01	02	03	04	05	06	07	08	09	0A	0B	0C	0D	0E	0F
10	11	12	13	14	15	16	17	18	19	1A	1B	1C	1D	1E	1F
20	!	"	#	\$	%	&	'	()	*	+	,	-	.	/
30	0	1	2	3	4	5	6	7	8	9	:	;	<	=	>
40	@	A	B	C	D	E	F	G	H	I	J	K	L	M	N
50	P	Q	R	S	T	U	V	W	X	Y	Z	[\]	^
60	`	a	b	c	d	e	f	g	h	i	j	k	l	m	n
70	p	q	r	s	t	u	v	w	x	y	z	{		}	~
80	€														
90															
A0	ı	ç	£	¤	¥	¦	§	¨	©	ª	«	¬	-	®	¯
B0	°	±	²	³	´	µ	¶	·	¸	¹	º	»	¼	½	¾
C0	À	Á	Â	Ã	Ä	Å	Æ	Ç	È	É	Ê	Ë	Ì	Í	Î
D0	Ð	Ñ	Ò	Ó	Ô	Õ	Ö	×	Ø	Ù	Ú	Û	Ü	Ý	Þ
E0	à	á	â	ã	ä	å	æ	ç	è	é	ê	ë	ì	í	î
F0	ð	ñ	ò	ó	ô	õ	ö	÷	ø	ù	ú	û	ü	ý	þ

44XXU070.eps



Note: You cannot print these characters as 4 x 4 inch graphics because there is white space surrounding the characters that prevents the image from reaching the maximum graphic size.

Characters in Font

c23 OCR A

00	01	02	03	04	05	06	07	08	09	0A	0B	0C	0D	0E	0F
10	11	12	13	14	15	16	17	—	19	1A	1B	1C	1D	1E	1F
	!	"	#	\$	%	&	'	()	*	+	,	-	.	/
20	21	22	23	24	25	26	27	28	29	2A	2B	2C	2D	2E	2F
0	1	2	3	4	5	6	7	8	9	:	;	<	=	>	?
30	31	32	33	34	35	36	37	38	39	3A	3B	3C	3D	3E	3F
@	A	B	C	D	E	F	G	H	I	J	K	L	M	N	O
40	41	42	43	44	45	46	47	48	49	4A	4B	4C	4D	4E	4F
P	Q	R	S	T	U	V	W	X	Y	Z	[\]	^	_
50	51	52	53	54	55	56	57	58	59	5A	5B	5C	5D	5E	5F
h	a	b	c	d	e	f	g	h	i	j	k	l	m	n	o
60	61	62	63	64	65	66	67	68	69	6A	6B	6C	6D	6E	6F
p	q	r	s	t	u	v	w	x	y	z	{		}	~	■
70	71	72	73	74	75	76	77	78	79	7A	7B	7C	7D	7E	7F
80	81	82	83	84	85	86	87	88	89	8A	8B	8C	8D	8E	8F
90	91	92	93	94	95	96	97	98	99	9A	9B	9C	9D	9E	9F
			£		¥										
A0	A1	A2	A3	A4	A5	A6	A7	A8	A9	AA	AB	AC	AD	AE	AF
B0	B1	B2	B3	B4	B5	B6	B7	B8	B9	BA	BB	BC	BD	BE	BF
C0				Ä	Å	Æ									
C0	C1	C2	C3	C4	C5	C6	C7	C8	C9	CA	CB	CC	CD	CE	CF
D0	Ñ					ö		ø				Ü			
D0	D1	D2	D3	D4	D5	D6	D7	D8	D9	DA	DB	DC	DD	DE	DF
E0	E1	E2	E3	E4	E5	E6	E7	E8	E9	EA	EB	EC	ED	EE	EF
F0	F1	F2	F3	F4	F5	F6	F7	F8	F9	FA	FB	FC	FD	FE	FF

44XXU071.eps

Characters in Font

c24 OCR B Size 2

00	01	02	03	04	05	06	07	08	09	0A	0B	0C	0D	0E	0F	
10	11	12	13	14	15	16	17	18	19	1A	1B	1C	1D	1E	1F	
20	!	"	#	\$	%	&	'	()	*	+	,	-	.	/	
30	0	1	2	3	4	5	6	7	8	9	:	;	<	=	>	?
40	@	A	B	C	D	E	F	G	H	I	J	K	L	M	N	O
50	P	Q	R	S	T	U	V	W	X	Y	Z	[\]	^	_
60	`	a	b	c	d	e	f	g	h	i	j	k	l	m	n	o
70	p	q	r	s	t	u	v	w	x	y	z	{		}	~	■
80																
90																
A0			£	ø	¥	¦	§	"								
B0				'				'								
C0				À	Á	Â										
D0	Ñ				Ö		Ø					Ü				ß
E0				ä	å	æ										
F0	ñ				ö		ø					ü				

44XXU072.eps

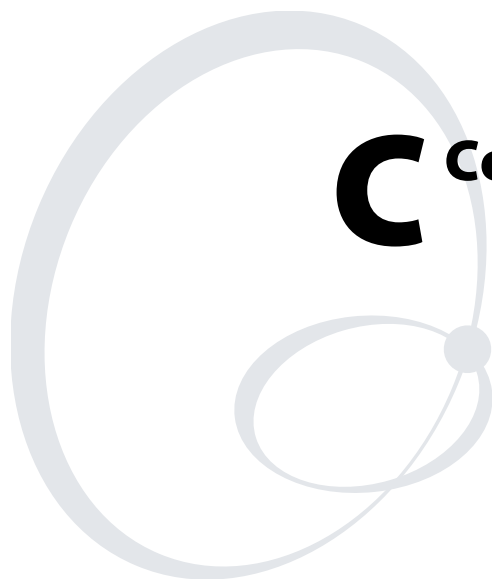

C Communications Reference

This chapter provides communications reference information. This chapter covers these topics:

- Communications protocols
- Communications interfaces
- Printer serial port

Communications Protocols

Communications protocols are important because they determine the transmission standards for communication between the printer and the host. The printer and the host must use the same protocol and parameters to communicate properly. The printer supports the flow control and block transfer protocols described in the next sections. All of these protocols are point-to-point except Multi-Drop. Application programs and/or ROM BIOS determine which protocols your computer can support. For more detailed information, refer to the Intermec *Data Communications Reference Manual* (P/N 044737).

Intermec Standard Protocol

Intermec Standard protocol is a proprietary block transfer/status response protocol. For each block sent, the host must wait for the appropriate response before sending the next block (<DC1>). Except for single character status commands (<ENQ> and <VT>), Standard protocol transmits characters in message blocks beginning with the start of text (<STX>) character and ending with the end of text (<ETX>) character. Message blocks can be up to 255 characters, including the start of text and end of text characters. The printer auto-discriminates between Standard, Polling Mode D, and Multi-Drop protocols.

The printer returns its highest priority status when it receives a valid block (<STX> data <ETX>) or when it receives the status request command <ENQ>. When the printer receives the status dump command (<VT>), the printer returns all active status. The printer status response time ranges from 30ms to 100ms depending on the complexity of the received message block. In the case of a transmission error, the printer responds with a <NAK> and discards the entire message block.

The next table shows printer status conditions in descending order of priority, status response characters, and pin 11/20 states.

Intermec Standard Protocol Printer Status Conditions

Printer Status	Character	Pin 11/20
Buffer already full	GS	Busy
Ribbon fault	US	Busy
No label stock	EM	Busy
Buffer now full	DC3	Busy
Printhead hot	SI	Busy
Offline (paused)	DC3	Busy
Label at strip pin	FS	Ready
Skipping	DC1	Ready

Intermec Standard Protocol Printer Status Conditions (continued)

Printer Status	Character	Pin 11/20
Printing	DC1	Ready
Ready/Online	DC1	Ready



Note: Do not confuse the Buffer now full <DC3> status with the XON/XOFF characters <DC1> and <DC3>.

When the printer returns Buffer Now Full (<DC3>) status, it accepts the currently received message block. At this time, the printer can accept short messages to allow parsing of immediate commands such as Reset (<DLE>) or Cancel Batch Printing (). However, if the printer responds with a <GS> to any message block, the buffer is already full and the printer discards the entire message block.

XON/XOFF Protocol (Software and Hardware Flow Control)

The XON/XOFF protocol stops the host from sending data when the printer buffer fills up and starts the host again when the buffer empties. When you select this protocol, you concurrently enable software and hardware flow control. Software flow control uses the ASCII characters <DC1> (XON) and <DC3> (XOFF) to start and stop the flow of data from the host to the printer. Hardware flow control uses pin 11 or pin 20 (internally connected together) on the printer's serial port to indicate "Ready" or "Busy" for data flow control. As with Standard protocol, <STX> and <ETX> enclose data. Status responses conform to the table above except that <DC2> is substituted for <DC1> and <DC4> is substituted for <DC3>.

The printer does not restrict the message length for XON/XOFF protocol. That is, the printer processes information as it is being downloaded and stops when there is no more information. There is no restriction on the number of characters that can be sent down at a time. <STX> and <ETX> are optional characters.

Pin 11/20 reports "Ready" and a <DC1> (XON) is transmitted when the printer finishes reloading at power-up. Pin 11/20 reports "Busy" when the printer's input buffer fills with 768 bytes of data. If the host ignores pin 11/20 and continues to transmit data, the printer transmits a <DC3> (XOFF) after receiving 15 additional characters. The printer continues to transmit a <DC3> after every 15 characters received if the host continues to transmit data. Data integrity is not guaranteed if this happens.

Pin 11/20 becomes "Ready" when the printer has transferred all the data from the input buffer. If the printer receives a <DC3>, it transmits a <DC1> (XON) and the host may resume transmission. When you switch the printer offline, pin 11/20 becomes "Busy" and it transmits a <DC3>.

When you switch the printer online (and the input buffer is empty), pin 11/20 becomes “Ready” and it transmits a DC1.

Printer XON/XOFF Operation

# of Bytes Received	Online/Offline	Pin 11/20	Transmit
Do not care	Offline	Busy	DC3
768	Online	Busy	
768 + each 15 thereafter	Online	Busy	DC3
Buffer Empty	Online	Ready	DC1 (if DC3 was sent)

XON/XOFF, No Status Protocol

This protocol is identical to XON/XOFF protocol except that status is not returned after each message received. However, status is still returned for the status request (<ENQ>) and the status dump (<VT>) commands.

Polling Mode D

Polling Mode D is a block transfer protocol that transmits data in blocks of up to 255 characters, including protocol overhead. For Polling Mode D, the host/concentrator is responsible for asking the printer for data it might have (polling) and requesting to send data to the printer (selecting). The blocks are framed with LRC characters for additional data integrity. Polling Mode D is normally used for point-to-point networks that connect the printer to an Intermec port concentrator (RS-232 or RS-422 are acceptable).

This protocol is the default setting for the printer. Return the protocol setting to Polling Mode D by setting the printer DIP switches to the factory default settings (9600, E, 7, 1).

Multi-Drop Protocol

Use Multi-Drop protocol to connect up to 32 devices to an Intermec controller on a four-wire RS-485 (two twisted pair). This protocol is similar to Polling Mode D except each device has a unique address (POL and SEL character). You must use an RS-485, which is automatically enabled when you enable Multi-Drop. Be sure to specify a unique address for the printer and verify that the baud rate is between 2,400 and 19,200.

User-Defined Protocol

The printer provides the capability to change protocol characters. However, users may not define their own protocol. You can substitute characters you want to use as protocol characters, but the rules for the chosen protocol do not change. The printer does not use any protocol characters that you replace with the NUL character. One table of protocol

characters exists. You may redefine these characters to create a table that all of the protocols can use. One possibility for the user to redefine protocol characters might be the replacement of control characters with printable characters.



Note: Please use caution when replacing control characters with printable characters. You cannot replace one control character with more than one printable character.

The following table lists the protocol characters that you can redefine and the protocols they affect.

Protocols Affected by Redefining Characters

Character	Protocol Affected
SELECT IN	POL MODE D, MULTI-DROP
POLL IN	POL MODE D, MULTI-DROP
RES IN	POL MODE D, MULTI-DROP
REQ IN	POL MODE D, MULTI-DROP
SOM IN	STD, POL MODE D, MULTI-DROP, XON/XOFF
EOM IN	STD, POL MODE D, MULTI-DROP, XON/XOFF
AFF IN	POL MODE D, MULTI-DROP
NEG IN	POL MODE D, MULTI-DROP
DLE IN	STD, POL MODE D, MULTI-DROP, XON/XOFF
XON IN	XON/XOFF
XOFF IN	XON/XOFF
SELECT OUT	MULTI-DROP
POLL OUT	MULTI-DROP
RES OUT	POL MODE D, MULTI-DROP
REQ OUT	POL MODE D, MULTI-DROP
SOM OUT	POL MODE D, MULTI-DROP
EOM OUT	POL MODE D, MULTI-DROP
AFF OUT	POL MODE D, MULTI-DROP
NEG OUT	STD, POL MODE D, MULTI-DROP
DLE OUT	STD, POL MODE D, MULTI-DROP
XON OUT	XON/XOFF
XOFF OUT	XON/XOFF
PROTO-CMD 1	STD, XON/XOFF
PROTO-CMD 2	STD, XON/XOFF
TIMEOUT ON EOM	POL MODE D, MULTI-DROP

Host Requirements

Your printer has the following hardware and software requirements:

- The host computer must use the American Standard Code for Information Exchange (ASCII) for data communications.
- A serial port must be available on the host if you are connecting directly to the printer.
- The host must support at least one of the following data communications interfaces: RS-232, RS-422, or RS-485.

For information on configuring the host computer, port concentrator, or network controller, see the reference manual for the controlling device.

Communications Boundaries

The information below applies to all protocols that the printer supports.

Communications Boundaries

Parameter	Maximum Capacity
Message delay	9999 milliseconds
Character delay	9999 milliseconds
Message block size	255 characters (including STX and ETX characters) Unlimited block size for XON/XOFF
Device address number (Multi-Drop only)	A to Z, 0 to 5

Communications Interfaces

The printer supports serial communications with the following interfaces:

- RS-232
- RS-422
- RS-485

The following sections describe these interfaces. See the *Data Communications Reference Manual* (P/N 044737) for more detailed information.

RS-232 Serial Interface

Use the RS-232 serial interface in all asynchronous point-to-point full- or half-duplex direct data communications or modem control. The printer cable must have the pin assignments for an RS-232 serial interface shown in the next table.

RS-422 Serial Interface

Use the RS-422 interface in long line point-to-point direct connect installations. The printer cable must have the pin assignments for an RS-422 serial interface shown in the next table.

RS-485 Serial Interface

Use the RS-485 serial interface for Multi-Drop installations only. The printer cable must have the pin assignments for an RS-485 serial interface shown in the next table.

RS-232, RS-422, and RS-485 Serial Interface Pin Assignments

Interface	Pin	Name	Operation
RS-232/422/485	1	Chassis Ground (GND)	Connect to pin 1, chassis ground, of connected device.
RS-232	2	Transmit Data (TD)	Output: Connect to receive data pin of connected device.
RS-232	3	Receive Data (RD)	Input: Connect to transmit data pin of connected device.
RS-232/422/485	4	Request to Send (RTS)	Output: When you use a modem, connect to modem RTS pin. The modem sets RTS to true before transmission. The printer sets RTS to false after transmission.
RS-232/422/485	5	Clear to Send (CTS)	Input: When you use a modem, connect to modem CTS pin. The modem must set CTS true before the printer transmits data. If not connected, CTS sets itself true.
RS-232/422/485	7	Signal Ground (SG)	To enable communications, connect to signal ground of connected device. Completes circuit for all RS-232 signals.
RS-232/422/485	11	Printer Status (PS)	Output: When not using software flow control (XON/XOFF), connect to input of connected device (for example, CTS). Indicates printer mechanical status and status of printer input buffer.
RS-422/485	13	Input B	Input: Serial differential data to the printer.
RS-422/485	14	Output A	Output: Serial differential data from the printer.
RS-422/485	16	Input A	Input: Serial differential data to the printer.
RS-422/485	19	Output B	Output: Serial differential data from the printer.
RS-232/422/485	20	Data Terminal Ready (DTR)	Output: When you use a modem, connect to modem DTR pin. When using Intermec Standard Protocol, this pin indicates that the printer is switched on. When using XON/XOFF or hardware flow control, this pin indicates the printer mechanical status and the status of the printer input buffer.

Printer Serial Port

The rear panel of the printer contains the serial port connector. It is a 25-pin D-style subminiature receptacle. The port is wired as a data terminal equipment (DTE) device.

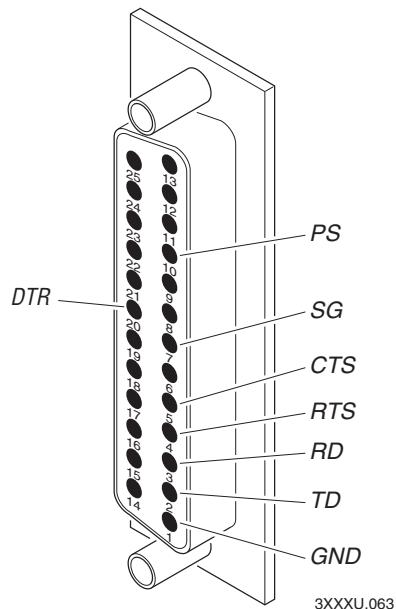

Serial port pin assignments: This illustration shows the serial port pin assignments.

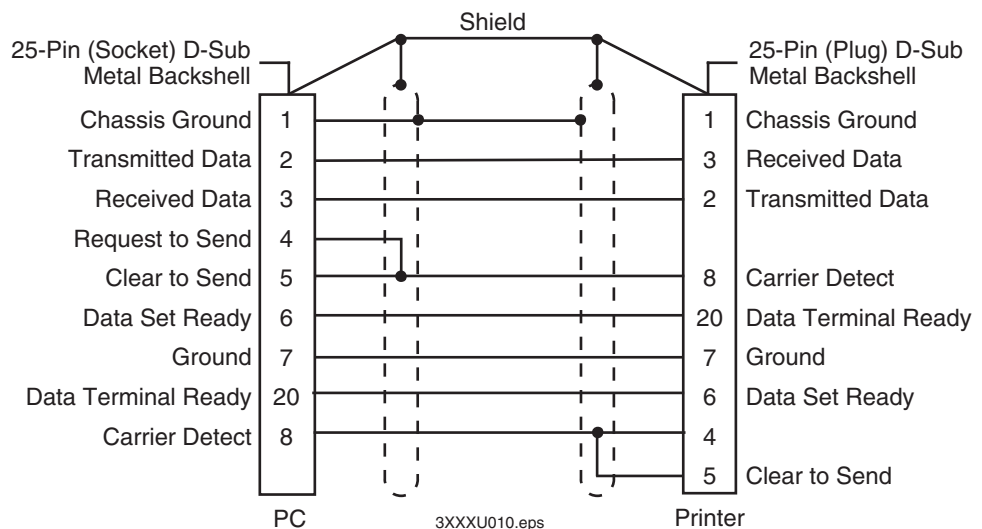

RS-232 null modem cable for PC/XT: This illustration shows the pin assignments for the RS-232 null modem cable for the PC/XT (P/N 048668).



Note: The metal backshell is connected directly to the shield to achieve electrostatic discharge (ESD) immunity.

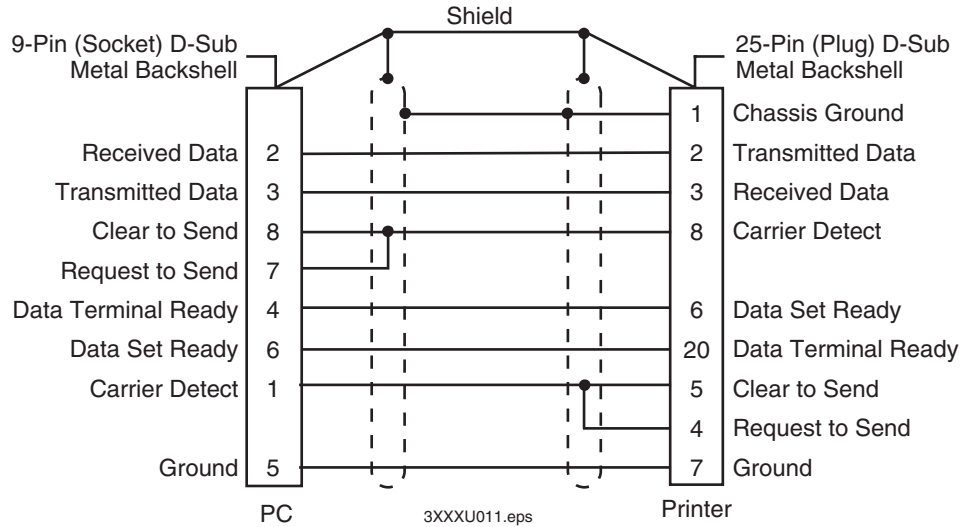

RS-232 for PC/AT: This illustration shows the pin assignments for the RS-232 null modem cable for PC/AT (P/N 048693).



Note: The metal backshell is connected directly to the shield to achieve electrostatic discharge (ESD) immunity.

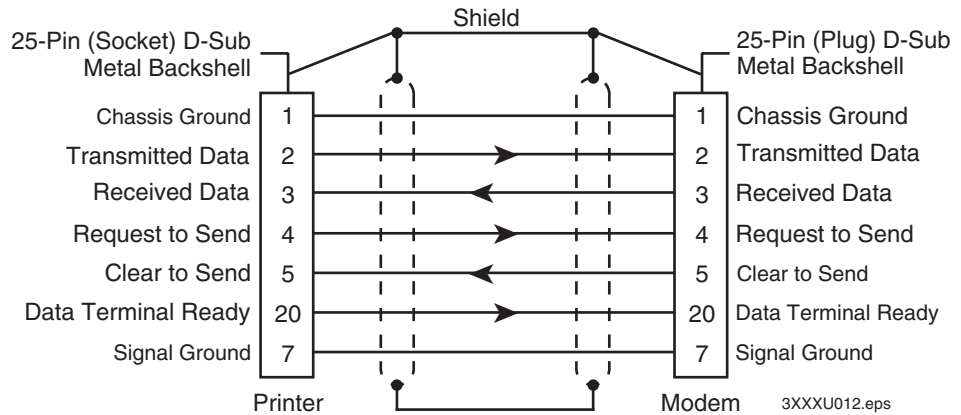

Straight through DTE to DCE cable: This illustration shows the pin assignments for the straight through DTE to DCE cable used with a modem (P/N 043237S). If you find that you are losing data, you may need to isolate the chassis ground from one of the two devices by connecting it to the shield.



Note: The metal backshell is connected directly to the shield to achieve electrostatic discharge (ESD) immunity.

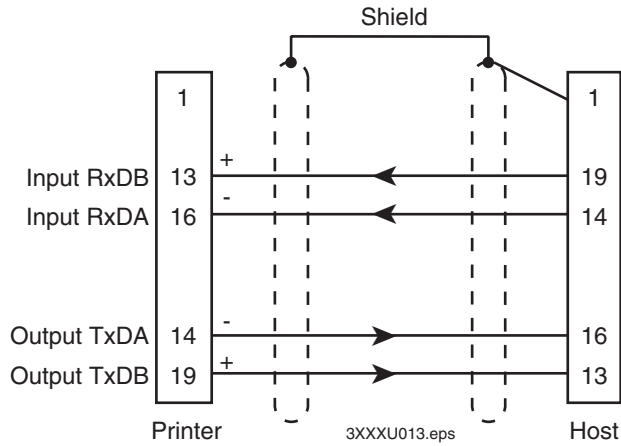

RS-422 serial interface: This illustration shows the pin assignments for the RS-422 serial interface. The host in this case includes Intermec products that support RS-422. Non-Intermec controllers may have different pin assignments.



Note: Connect pin 1 to shield at one end only.



D Full ASCII Table

This chapter contains these tables:

- Full ASCII table
- Full ASCII control characters table

Full ASCII Table

This table lists the ASCII characters and their binary, hexadecimal, decimal, and Code 39 equivalents.

Full ASCII Table

Binary ⁰	Hex ¹	Dec ²	C39 ³	Char ⁴	Binary ⁰	Hex ¹	Dec ²	C39 ³	Char ⁴
00000000	00	00	%U	NUL	00100010	22	34	/B	"
00000001	01	01	\$A	SOH	00100011	23	35	/C	#
00000010	02	02	\$B	STX	00100100	24	36	/D	\$
00000011	03	03	\$C	ETX	00100101	25	37	/E	%
00000100	04	04	\$D	EOT	00100110	26	38	/F	&
00000101	05	05	\$E	ENQ	00100111	27	39	/G	'
00000110	06	06	\$F	ACK	00101000	28	40	/H	(
00000111	07	07	\$G	BEL	00101001	29	41	/I)
00001000	08	08	\$H	BS	00101010	2A	42	/J	*
00001001	09	09	\$I	HT	00101011	2B	43	/K	+
00001010	0A	10	\$J	LF	00101100	2C	44	/L	,
00001011	0B	11	\$K	VT	00101101	2D	45	/M	-
00001100	0C	12	\$L	FF	00101110	2E	46	/N	.
00001101	0D	13	\$M	CR	00101111	2F	47	/O	/
00001110	0E	14	\$N	SO	00110000	30	48	/P6	0
00001111	0F	15	\$O	SI	00110001	31	49	/Q	1
00010000	10	16	\$P	DLE	00110010	32	50	/R	2
00010001	11	17	\$Q	DC1	00110011	33	51	/S	3
00010010	12	18	\$R	DC2	00110100	34	52	/T	4
00010011	13	19	\$S	DC3	00110101	35	53	/U	5
00010100	14	20	\$T	DC4	00110110	36	54	/V	6
00010101	15	21	\$U	NAK	00110111	37	55	/W	7
00010110	16	22	\$V	SYN	00111000	38	56	/X	8
00010111	17	23	\$W	ETB	00111001	39	57	/Y	9
00011000	18	24	\$X	CAN	00111010	3A	58	/Z	:
00011001	19	25	\$Y	EM	00111011	3B	59	%F	;
00011010	1A	26	\$Z	SUB	00111100	3C	60	%G	<
00011011	1B	27	%A	ESC	00111101	3D	61	%H	=
00011100	1C	28	%B	FS	00111110	3E	62	%I	>
00011101	1D	29	%C	GS	00111111	3F	63	%J	?
00011110	1E	30	%D	RS	01000000	40	64	%V	@
00011111	1F	31	%E	US	01000001	41	65	A	A
00100000	20	32	SP	SP5	01000010	42	66	B	B
00100001	21	33	/A	!	01000011	43	67	C	C

Full ASCII Table (continued)

Binary ⁰	Hex ¹	Dec ²	C39 ³	Char ⁴	Binary ⁰	Hex ¹	Dec ²	C39 ³	Char ⁴
01000100	44	68	D	D	01100011	63	99	+C	c
01000101	45	69	E	E	01100100	64	100	+D	d
01000110	46	70	F	F	01100101	65	101	+E	e
01000111	47	71	G	G	01100110	66	102	+F	f
01001000	48	72	H	H	01100111	67	103	+G	g
01001001	49	73	I	I	01101000	68	104	+H	h
01001010	4A	74	J	J	01101001	69	105	+I	i
01001011	4B	75	K	K	01101010	6A	106	+J	j
01001100	4C	76	L	L	01101011	6B	107	+K	k
01001101	4D	77	M	M	01101100	6C	108	+L	l
01001110	4E	78	N	N	01101101	6D	109	+M	m
01001111	4F	79	O	O	01101110	6E	110	+N	n
01010000	50	80	P	P	01101111	6F	111	+O	o
01010001	51	81	Q	Q	01110000	70	112	+P	p
01010010	52	82	R	R	01110001	71	113	+Q	q
01010011	53	83	S	S	01110010	72	114	+R	r
01010100	54	84	T	T	01110011	73	115	+S	s
01010101	55	85	U	U	01110100	74	116	+T	t
01010110	56	86	V	V	01110101	75	117	+U	u
01010111	57	87	W	W	01110110	76	118	+V	v
01011000	58	88	X	X	01110111	77	119	+W	w
01011001	59	89	Y	Y	01111000	78	120	+X	x
01011010	5A	90	Z	Z	01111001	79	121	+Y	y
01011011	5B	91	%K	[01111010	7A	122	+Z	z
01011100	5C	92	%L	\	01101100	6C	108	+L	l
01011101	5D	93	%M]	01111011	7B	123	%P	{
01011110	5E	94	%N	^	01111100	7C	124	%Q	
01011111	5F	95	%O	_	01111101	7D	125	%R	}
01100000	60	96	%W	`	01111110	7E	126	%S	~
01100001	61	97	+A	a	01111111	7F	127	%T ⁷	n ⁸
01100010	62	98	+B	b					

Notes for the Full ASCII Table

- | | | | |
|---|-----------------------------|---|--|
| 0 | Bit positions are 76543210. | 5 | SP is the SPACE character. |
| 1 | Hexadecimal value. | 6 | The Code 39 characters /P through /Y may be interchanged with the numbers 0 through 9. |
| 2 | Decimal value. | 7 | May be interchanged with %X or %Y or %Z. |
| 3 | Code 39 characters. | 8 | n is the DELETE character. |

Full ASCII Control Characters Table

This table lists the ASCII control characters and their definitions.

Full ASCII Control Characters Table

Control Character	Definition	Control Character	Definition
ACK	Acknowledgment	FF	Form Feed
BEL	Bell	FS	File Separator
BS	Backspace	GS	Group Separator
CAN	Cancel	HT	Horizontal Tab
CR	Carriage Return	LF	Line Feed
DC1	Device Control 1 (XON)	NAK	Negative Acknowledge
DC2	Device Control 2	NUL	Null, or all zeroes
DC3	Device Control 3 (XOFF)	RS	Record Separator
DC4	Device Control	SI	Shift In
DEL	Delete	SO	Shift Out
DLE	Data Link Escape	SOH	Start of Heading
EM	End of Medium	SP	Space
ENQ	Enquiry	STX	Start of Text
EOT	End of Transmission	SUB	Substitute
ESC	Escape	SYN	Synchronous Idle
ETB	End Transmission Block	US	Unit Separator
ETX	End of Text	VT	Vertical Tab



G Glossary

ASCII

American Standard Code for Information Interchange. A standard seven-bit code almost always transmitted with a parity bit for a total of eight bits per character. ASCII was established by the American National Standards Institute to achieve compatibility between various types of data communication equipment. Equivalent to the International ISO 7-bit code.

backing

Silicon release liner on media to which labels are attached until ready for use.

bar code

A printed, machine-readable code that consists of parallel bars of varied width and spacing.

batch takeup

A device that rewinds media; useful for printing batches of labels.

BEL

A command character that instructs the printer to return an error status code.

character set

Refers to the letters, numerals, and symbols that support a particular language (such as French, U.S., ASCII) or automatic identification technology (such as Code 30, Codabar).

cloning

A procedure that copies the RAM contents (configuration, formats, fonts, pages and graphics) from the memory of one printer to the memory of another.

configuration

The current parameter settings that determine the operating characteristics of the printer.

data file

The collection of data and printer commands that, when sent to the printer, is merged with a format file to print a label.

Data Line Print mode

A mode of operation in which the printer prints each command (accompanied by its ASCII code) that it receives from the host.

density

Number of data characters that can be represented in a linear unit of measure. Often expressed in characters per inch.

direct thermal

A method of thermal printing in which images are printed when heat from the thermal printhead produces a black mark on the media.

EAN

European Article Numbering; now also called IAN (International Article Numbering). International standard bar code for retail food packages corresponding to the Universal Product Code (UPC) in the United States.

Emulation mode

An operating mode in which the printer has the operating characteristics of an 8636 or 8646 printer.

Feed/Pause button

A printer control panel button that advances the media and causes the printer to pause printing.

field

A graphic element that is the basic unit of a format. The four basic types of fields are bar code, graphic, line, and text.

fixed data field

Bar code and text fields that never vary from one label to the next; the data in a fixed field is a permanent part of the format.

fixed format

A format in which the data never varies from one label to the next, such as a return address label. A fixed format needs no additional data to print a label.

font

A character set of a given type size and style. See also character set.

font file

See soft font.

format file

a collection of printer commands and data that determines the arrangement of fields on a label.

graphic

A bitmap picture downloaded to the printer by the host before printing.

HIBC

Health Industry Bar Code standard. A modified version of Code 39 that has 43 characters, utilizes the Modulus 43 check character, and reserves some character combinations for special usage.

human-readable

A character, number, or symbol printed in a font that can be read by a human; as opposed to bar code symbology, which can only be read by a machine. See text.

image bands

A portion of an image in the shape of a strip of the image. A certain number of image bands are stored in memory before printing begins. This method allows printing and imaging to take place simultaneously.

imaging

The process of generating a picture of the label in printer memory.

ips

Inches per second. A measurement of print speed that measures the number of inches of media that is printed each second.

ISO

International Organization for Standardization. An internationally accepted 7-bit character code. (The U.S. version is ASCII.)

label

The part of the media on which data is printed.

label format

The design of a bar code label; the arrangement of the text, lines, and bar codes on a label.

label gap

The space between labels on die-cut label stock.

ladder

A method of bar code printing in which the bars in the bar code print one at a time, in a series. The bar code appears along the length of the label.

margin

The distance between the edge of a label and where the printing starts on that label. *See also* top of form.

media

The label stock on which the printer prints labels. Media can be made of plain paper, polyester, thermally reactive paper, or other materials with adhesive backing and ribbon.

mnemonic code

An acronym or abbreviation for a computer instruction, routine, or format. For example, <STX> represents the start of text.

Multi-Drop protocol

A protocol capable of controlling communications between a single controller and multiple devices.

OCR font

A font that is recognized by optical character recognition.

offline

The state in which the printer is not able to carry out two-way communication with the host.

online

The state in which the printer is able to carry out two-way communication with the host.

parallel

A communication scheme in which the bits of a byte are transferred simultaneously over a multistrand cable.

parameters

The operating limits of the printer. Also, the variable information sent with a command.

picket

A method of bar code printing in which all the bars are printed at once, in parallel. The bar code appears across the width of the label.

pitch

(1) The number of characters printed in one horizontal inch determined by the increment by which the printer platen moves. (2) Rotation of a bar code symbol about an axis parallel to the direction of the bars.

point size

A unit of measure for font height; 72 points equals 1 inch as measured from slightly above the top of the uppercase letters to slightly below the bottom of the lowercase descenders.

Polling Mode D protocol

Polling Mode D is a protocol that allows devices and controllers to exchange data in an “ask and receive” format. Use Polling Mode D to connect multiple devices to a single multiport controller.

print speed

Measured in inches per second (ips), the rate at which media travels past the printhead.

printhead

The mechanism inside the printer that prints. For example, the printhead for the 3440 printer consists of 1792 thermal elements.

printhead elements

The parts of the printhead that print by placing a mark on the label when heated. Each element is switched on and off separately in order to react with the media or thermal transfer ribbon to create a mark on the label.

ready

The state in which the printer is able to print; the normal operating state of the printer.

Ready/Busy line

Pin 11/20 of the rear panel connector. Indicates the printer is ready or not ready.

RS-232

Widely recognized protocol standard for serial binary data interchange. The standard covers the physical, electrical, and functional characteristics of the interface.

RS-422

Standard for the voltage and impedance levels for serial data transmission on balanced lines. Similar to RS-232, but handles larger distances and faster communication.

RS-485

Standard for allowing multiple devices to share a common set of serial data communication lines. The signaling is very similar to RS-422. The maximum number of devices allowed is 32.

scan

To read a bar code with a device known as a scanner that converts optical information into electrical signals.

selective transfer

A procedure that copies selected formats, fonts, graphics, or pages stored in the memory of one printer to the memory of another.

self-strip

An internal device for the printer that presents each label after it is printed, with the backing removed so it may be applied immediately. Self-strip is a standard feature on the 3400e printer.

sensitivity

The responsiveness of thermal media, or of thermal transfer ribbon, to heat; it is determined by the time required for a unit measure of heat to affect the media or ribbon.

serial

A communication scheme in which the bits of a byte are transferred one at a time. Often serial transmission is used to link host computers to terminals and PCs to printers.

soft font

A file stored in the printer to provide the ability to print text using fonts that are not resident in the printer.

Standard protocol

A communications protocol capable of controlling communications between two devices connected by a single data communication line.

symbology

A scheme for encoding data as a bar code. Code 39, Interleaved 2 of 5, and Code One are examples of different symbologies.

thermal transfer

A method of printing by which heat from the printhead melts ink from the ribbon onto media. The ink adheres to the media as it cools.

top of form

The point where printing can start on a label. Separated from the edge of the label by the margin.

UPC

Universal Product Code. A numeric, 12-digit bar code symbology used extensively in retail, particularly the grocery industry.

User-Defined Characters (UDC)

See graphic.

User-Defined Fonts (UDF)

See soft font.

variable data field

Bar code and text fields that change from one label to the next.

XON/XOFF protocol

A protocol that stops the host from sending data when the printer buffer fills up and starts it again when the buffer empties.



Index

Numbers

- 2D symbologies
 - Code 16K, 74
 - Code 49, 75
 - Data Matrix, 75
 - described, 74
 - Maxicode, 75
 - PDF417, 75
 - QR Code, 76
- 86XX Emulation mode, 62

A

- AC power receptacle, 3
- adjustments
 - bias adjust screw, 48
 - darkness adjust control, 49
 - label mark sensor, 50
 - X forms adjust, 64
 - Y forms adjust, 65
- Advanced mode, international character sets, 78
- Alert LED, troubleshooting, 43
- AS400, connecting to the 3400, 10
- ASCII
 - definition, 100
 - table, 96, 97

B

- backing, definition, 100
- bands, image, 53
- bar code
 - definition, 100
 - symbologies
 - 2D matrix
 - Data Matrix, 75
 - list of, 75
 - Maxicode, 75
 - QR Code, 76
 - 2D stacked
 - Code 16K, 74
 - Code 49, 75
 - list of, 74
 - PDF417, 75
 - Codabar, 73
 - Code 11, 73
 - Code 128, 73
 - Code 2 of 5, 73
 - Code 39, 73
 - Code 93, 73
 - EAN, 74
 - Interleaved 2 of 5, 74
 - list of, 73
 - POSTNET, 74
 - UPC, 74
- batch takeup, definition, 100
- BEL, definition, 100
- bias adjust screw
 - adjusting, 48
 - using for optimal print quality, 48
- boundaries, communication, 90

C

- cables
 - considerations in noisy electrical environments, 11
 - RS-232 schematics, 92
 - RS-422 schematic, 94
 - serial port, 9
 - straight through schematics, 93
- changing core-locking brackets, 22
- character sets, 68
 - Advanced mode, 78
 - Code Page 850, 80
 - definition, 100
 - Emulation mode, 78
 - extended, 81
 - IBM translation, 79
 - international, 78
- cleaning
 - drive roller, 36
 - label sensors, 38
 - media guides, 37
 - media path, 37
 - printer covers, 36
 - printhead, 34
 - schedule, 32
 - tear bar, 36
 - tools, 32
- cloning, definition, 100
- coax interface option, 71
- Codabar, 73
- Code 11, 73
- Code 128, 73
- Code 16K, 74
- Code 2 of 5, 73
- Code 39, 73
- Code 49, 75
- Code 93, 73
- Code Page 850, character table, 80
- communicating with the printer, 28
 - using PrintSet, 28
 - using the printer command set, 28
 - using third-party software, 28
- communications
 - boundaries, 90
 - host requirements, 90
 - interfaces, 90
 - IPL commands, using, 28
 - PrintSet, using, 28
 - protocols, 86
 - Multi-Drop, 88
 - Polling Mode D, 88
 - Standard, 86
 - user-defined, 89
 - XON/XOFF, 87, 88
 - specifications, 68
 - testing for, 13, 29
 - third-party software, using, 28
 - troubleshooting, 45, 46, 58

- configuration
 - definition, 100
 - printing test label, 29, 58
 - test label
 - hardware, 7
 - software, 25
 - troubleshooting, 43
- configuration commands
 - changing from Test and Service mode, 59
 - Emulation mode, 62
 - X forms adjust, 64
 - Y forms adjust, 65
 - DIP switch settings, 59
- connecting
 - printer to a mainframe, 11
 - printer to a network, 10
 - printer to a PC
 - using the parallel port, 9
 - using the serial port, 9
 - printer to an AS400, 10
 - printer to power source, 3
 - printer to system
 - using the parallel port, 8
 - using the serial port, 8
- core-locking brackets, changing, 22
- cover
 - cleaning, 36
 - removing, 4
- D**
- darkness adjust control
 - setting, 49
 - using for optimal print quality, 49
- data file, definition, 100
- Data Line Print, 58
 - definition, 100
 - entering, 58
 - using to test the operation of the printer, 58
 - using to troubleshoot printer, 58
- data loss
 - checking for communication problems, 46
 - preventing, 46
- Data Matrix, 75
- density, definition, 101
- dimensions, 68
- DIP switch settings
 - changing, 12
 - chart, 13
 - configuration commands, 59
 - descriptions, 12
 - test and service, 57
- direct thermal, definition, 101
- dot increments, setting the number of, 60
- downloading, definition, 28
- drive roller, cleaning, 36
- E**
- EAN
 - definition, 101
 - described, 74
- EasyLAN 10i interface option, 71
- EasyLAN 10i2 adapter accessory, 71
- EasyLAN Wireless interface option, 71
- electrical requirements, 68
- empty/pause LED, troubleshooting, 45
- Emulation mode
 - definition, 101
 - international character sets, 78
- environment, specifications, 68
- Ethernet interface option. *See* EasyLAN 10i interface option.
- extended character sets, 81
- F**
- fanfold media, loading, 5
- faults, media or system, 17
- Feed/Pause button
 - definition, 101
 - functions of, 17
 - illustrated, 16
 - using, 17
- field, definition, 101
- fixed data field, definition, 101
- fixed format, definition, 101
- flash SIMM, additional storage memory, 52
- flow control, 87
- font
 - and graphics specifications, 69
 - definition, 101
 - extended character sets, 81
 - file, definition, 101
- format
 - file, definition, 101
 - positioning with DIP switches, 63
- forms adjust
 - positioning the label format, 63
 - X forms, setting, 64
 - Y forms, setting, 65
- front panel
 - LEDs, 16
 - understanding, 16
- full ASCII table, 96, 97
- G**
- graphic
 - definition, 102
 - specifications, 69
- H**
- hardware configuration test label, printing, 7
- HIBC, definition, 102
- host requirements, communications, 90
- human-readable, definition, 102

Index

I

IBM translation, character table, 79
image bands
 definition, 102
 description, 53
 function, 54
 optimizing with print speed, 54
imaging, definition, 102
increasing printer throughput, 53
inspecting the printer, 32
installing, printer, 3
interfaces
 communications, 90
 EasyLAN 10i, 71
 EasyLAN 10i2 adapter accessory, 71
 EasyLAN Wireless, 71
 RS-232, 90
 RS-422, 91
 RS-485, 91
Interleaved 2 of 5, 74
Intermec Standard protocol, described, 86
international character sets, 78
IPL commands, using to communicate, 28
ips, definition, 102
ISO, definition, 102

K

Kanji/Katakana option, 72

L

label
 definition, 102
 format
 definition, 102
 positioning along the length of label, 64
 positioning parallel along width of label, 65
 gap, definition, 102
 mark sensor, adjusting, 50
 rest point, setting dot increments, 60
 sensors, cleaning, 38
ladder, definition, 102
languages, international character sets, 78
LED
 front panel, 16
 indicators, 16
 media or system faults, 17
 over-temperature condition, 17
 understanding, 16
loading
 fanfold media, 5
 media for straight-through printing, 18
 roll media, 18
 thermal transfer ribbon, 22, 23

M

mainframe, connecting to the 3400, 11
maintenance
 location of parts to be maintained, 34
 schedule, 32

margin, definition, 103
matrix symbologies. *See* 2D symbologies.
Maxicode, 75
media
 definition, 103
 fault, troubleshooting, 43
 guides, cleaning, 37
 loading fanfold, 5
 loading in the printer, 18
 path, cleaning, 37
 specifications, 69
media or system faults, 17
media sensitivity number
 description of, 24
 setting for Intermec media and ribbon, 25
 settings table
 direct thermal media, 26, 27
 thermal transfer media, 27
memory
 additional storage, flash SIMM, 52
 expansion option, 72
 increasing amount available, 52, 58
 limitations, 52
 resetting, 58
 returning printer to default settings, 58
 usage
 limitations, 52
 problems, 52
 using efficiently, 52
mnemonic code, definition, 103
MSN. *See* media sensitivity number.
Multi-Drop protocol
 definition, 103
 described, 88

N

network, connecting to the 3400, 10

O

OCR font, definition, 103
offline, definition, 103
On/Off switch, 3
online, definition, 103
opening the printer, 4
operation problems, troubleshooting, 42
options
 communication interface, 71
 finishers, 72
 printer, 71
over-temperature condition, 17

P

parallel
 definition, 103
 interface, pin descriptions, 72
 port, using to connect the 3400 to a PC, 9
parameters, definition, 103
PDF417, 75
picket, definition, 103

- pin descriptions, parallel interface, 72
 - pitch
 - definition, 103
 - test label, printing, 58
 - plugging in the printer, 3
 - point size, definition, 104
 - Polling Mode D protocol
 - definition, 104
 - described, 88
 - POSTNET, 74
 - power loss, troubleshooting, 42
 - preparing the printer for installation, 3
 - preventing data loss, 46
 - print quality
 - correcting, 48
 - darkness adjust control, adjusting with, 49
 - maintaining, 48
 - optimizing, 48
 - printing test label, 58
 - troubleshooting, 44
 - understanding, 48
 - print speed
 - adjusting for use with image bands, 54
 - definition, 104
 - printer
 - communication problems, 45
 - communications, 28, 68
 - components
 - back view, 3
 - front view, 2
 - connecting
 - AS400, 10
 - mainframe, 11
 - network, 10
 - PC, 9
 - to power, 3
 - to your system, 8
 - cover
 - cleaning, 36
 - removing, 4
 - features, described, 2
 - inspection, 32
 - installing, 3
 - memory, using efficiently, 52
 - opening, 4
 - operation
 - testing, 58
 - troubleshooting, 42, 58
 - options, 71
 - coax interface, 71
 - EasyLAN 10i interface, 71
 - EasyLAN 10i2 adapter accessory, 71
 - EasyLAN Wireless, 71
 - Kanji/Katakana, 72
 - memory expansion, 72
 - twinax interface, 71
 - plugging in, 3
 - ports, illustrated, 8
 - RAM
 - allocation, 52
 - storage limitations, 52
 - understanding, 52
 - serial port, 92
 - printhead
 - cleaning, 34
 - definition, 104
 - elements, definition, 104
 - specifications, 70
 - printing
 - hardware configuration label, 7
 - increasing speed, 53
 - software configuration label, 25
 - speed, specifications, 70
 - straight-through, 18
 - test label, 29
 - PrintSet, using to communicate with the printer, 28
 - problems
 - communication, 45
 - print quality, 44
 - printer operation, 42
 - protocols
 - described, 86
 - Multi-Drop, 88
 - Polling Mode D, 88
 - Standard, 86
 - user-defined, 89
 - XON/XOFF, 87, 88
- ## Q
- QR Code, 76
 - quality, problems, troubleshooting, 44
- ## R
- RAM, using efficiently, 52
 - ready, definition, 104
 - Ready/Busy line, definition, 104
 - removing the printer cover, 4
 - requirements
 - electrical, 68
 - hardware and software, 90
 - resetting, memory, 58
 - ribbon specifications, 70
 - RS-232
 - definition, 104
 - serial interface
 - described, 90
 - RS-422
 - definition, 104
 - serial interface
 - described, 91
 - RS-485
 - definition, 104
 - serial interface
 - described, 91

Index

S

scan, definition, 105
schedule of maintenance, 32
selective transfer, definition, 105
self-strip
 definition, 105
 printing
 loading media, 20
 specifications, 70
sensitivity, definition, 105
serial
 definition, 105
 port
 cables, 9
 description, 92
 pin assignments, illustrated, 92
 using to connect a PC to the 3400, 9
setting
 dot increments, number of, 60
 media sensitivity number, 24, 25
soft font, definition, 105
software configuration label, printing, 25
speed, printing, 70
stacked symbologies. *See* 2D symbologies.
Standard protocol
 definition, 105
 described, 86
straight-through printing, 18
symbologies
 2D, described, 74
 Codabar, 73
 Code 11, 73
 Code 128, 73
 Code 16K, 74
 Code 2 of 5, 73
 Code 39, 73
 Code 49, 75
 Code 93, 73
 Data Matrix, 75
 EAN, 74
 Interleaved 2 of 5, 74
 Maxicode, 75
 PDF417, 75
 POSTNET, 74
 QR Code, 76
 UPC, 74
symbology, definition, 105

T

tear bar, cleaning, 36
Test and Service mode
 86XX Emulation mode, 62
 changing configuration commands from, 59
 Data Line Print, 58
 DIP switch settings, 57
 entering, 56
 exiting, 56
 memory reset, 58

 printing test labels, 58
 using forms adjust, 63
 X forms adjust, 64
 Y forms adjust, 65
test label
 example of hardware configuration, 7
 printing, 29, 58
thermal transfer
 definition, 105
 ribbon, loading, 22, 23
third-party software, 28
throughput, increasing, 53
top of form, definition, 105
troubleshooting
 checklist, 42
 communication problems, 45
 data loss, 46
 print quality problems, 44
 printer operation problems, 42
twinax interface option, 71

U

UDC, definition. *See* graphic, definition.
UDF, definition. *See* soft font, definition.
UPC
 definition, 106
 described, 74
uploading, definition, 28
user-defined protocol, 89

V

variable data field, definition, 106

X

X forms adjust
 default origin, 64
 setting dot increments, 60
 setting with DIP switches, 64
 See also top of form, set command.
XON/XOFF
 definition, 106
 described, 87
 no status protocol, 88

Y

Y forms adjust
 default origin, 64
 setting dot increments, 60
 setting with DIP switches, 65
yellow LED, troubleshooting, 45



Worldwide Headquarters
6001 36th Avenue West
Everett, Washington 98203
U.S.A.

tel 425.348.2600

fax 425.355.9551

www.intermec.com

EasyCoder 3400e Bar Code Label Printer User's Manual



P/N 071881-003