

The Intermec logo is displayed in a bold, blue, sans-serif font. It is positioned on the left side of the page, partially overlaid by a large, light blue graphic consisting of several overlapping circles and lines, resembling a stylized atom or a network diagram. A vertical red line extends from the top of the page down to the bottom, passing through the center of the Intermec logo and the 'User's Guide' text.

User's Guide



EasyCoder® PD41
Printer

Intermec Technologies Corporation

Corporate Headquarters

6001 36th Ave.W.

Everett, WA 98203

U.S.A.

www.intermec.com

The information contained herein is proprietary and is provided solely for the purpose of allowing customers to operate and service Intermec-manufactured equipment and is not to be released, reproduced, or used for any other purpose without written permission of Intermec.

Information and specifications contained in this document are subject to change without prior notice and do not represent a commitment on the part of Intermec Technologies Corporation.

© 2005, 2006 by Intermec Technologies Corporation. All rights reserved.

The word Intermec, the Intermec logo, Norand, ArciTech, CrossBar, Data Collection Browser, dcBrowser, Duratherm, EasyADC, EasyCoder, EasyLAN, Enterprise Wireless LAN, EZBuilder, Fingerprint, i-gistics, INCA (under license), InterDriver, Intermec Printer Network Manager, IRL, JANUS, LabelShop, Mobile Framework, MobileLAN, Nor*Ware, Pen*Key, Precision Print, PrintSet, Ready-to-Work, RoutePower, SmartSystems, TE 2000, Trakker Antares, and Virtual Wedge are either trademarks or registered trademarks of Intermec Technologies Corporation.

Throughout this manual, trademarked names may be used. Rather than put a trademark (™ or ®) symbol in every occurrence of a trademarked name, we state that we are using the names only in an editorial fashion, and to the benefit of the trademark owner, with no intention of infringement.

There are U.S. and foreign patents pending.

Microsoft, Windows, and the Windows logo are registered trademarks of Microsoft Corporation in the United States and/or other countries.

Contents

Before You Begin	vii
Safety Information	vii
Global Services and Support	viii
Warranty Information	viii
Web Support	viii
Telephone Support	viii
Who Should Read This Manual	ix
Related Documents	ix
1 Getting Started	1
Description of EasyCoder PD41	2
Unpacking the Printer	2
Product Identification	4
Front View	4
Controls and Indicators	5
Rear View	6
Connectors	6
Media Compartment	7
Print Mechanism	7
Installing the Printer	8
Fingerprint and IPL	8
Connecting the Printer to your System	9
Connecting the Printer through the USB interface	9
Connecting the Printer through the Serial Port	9
Connecting the Printer to a Network	9
Connecting the Printer through the Parallel Port	10
Printing a Test Label	10
2 Operating the Printer	13
Loading Media	14
Tear-Off (straight-through) Operation	14
Tear-Off	14
Peel-Off (Self-Strip) Operation	17
Peel-Off	17
Loading Thermal Transfer Ribbon	20
Loading Ribbon	20

LED indicators and the Print Button	23
LED indicators.	23
Print Button.	24
3 Maintaining the Printer	27
General Maintenance Advice	28
Printhead Cleaning.	28
Internal Cleaning	29
External Cleaning	29
4 Troubleshooting	31
Printer Operation Problems	32
Print Quality Problems.	33
Ready-to-Work™ Indicator	34
Ready-to-Work LED Flashing or Off.	34
Troubleshooting Adjustments	34
Ribbon Wrinkling Adjustments	34
Clearing Media Jams	35
Printhead Adjustments	36
Label Gap Sensor Adjustments.	39
5 Setting up the Printer	41
The Printer Startup Sequence	42
Changing Configuration Settings	44
Using PrintSet 4.	44
Using the Printer's Home Page	44
Using the Command Line	44
Running Testmode	45
Testmode	45
Extended Testmode	47
Upgrading Firmware.	51

A Technical Data.....53

Printer Specifications.....54

B Media Specifications.....57

Media Roll Sizes58

Core58

Internal Roll58

Ribbon Size59

Paper Types and Sizes60

Non-Adhesive Strip60

Self-Adhesive Strip61

Self-Adhesive Labels62

Tickets with Gaps.....64

Tickets with Black Mark.....66

C Setup Parameters (Fingerprint).....69

Setup Description70

Serial Communication Setup70

Feed Adjust Setup72

Media Setup73

Media Size73

Paper Type76

Direct Thermal Printing76

Thermal Transfer printing.....77

Contrast.....78

Print Definitions.....78

D Setup Parameters (IPL).....79

Setup Description80

About Test labels80

Serial Communication Setup80

Media Setup	83
Configuration Setup	86
Returning to Factory Default Setup	87

E Interfaces 89

RS-232 Serial Interface	90
Protocol	90
Interface cable	90
USB Interface	91
EasyLAN Ethernet Interface	92
Parallel IEEE 1284 Interface	92
Interface cable	92

F Options 95

EasyLAN Ethernet Interface	96
Parallel IEEE 1284 Interface	96
Cutter Kit	96
Internal Rewinder	96
Printhead Kit	96

Before You Begin

This section provides you with safety information, technical support information, and sources for additional product information.

Safety Information

Your safety is extremely important. Read and follow all warnings and cautions in this document before handling and operating Intermec equipment. You can be seriously injured, and equipment and data can be damaged if you do not follow the safety warnings and cautions. Be sure to read the *EasyCoder PD41 Safety Instructions*, where the basic safety precautions regarding the operation of the PD41 are described and illustrated.

This section explains how to identify and understand warnings, cautions, and notes that are in this document. You may also see icons that tell you when to follow ESD procedures.



A warning alerts you of an operating procedure, practice, condition, or statement that must be strictly observed to avoid death or serious injury to the persons working on the equipment.



A caution alerts you to an operating procedure, practice, condition, or statement that must be strictly observed to prevent equipment damage or destruction, or corruption or loss of data.



This icon appears at the beginning of any procedure in this manual that could cause you to touch components (such as printed circuit boards) that are susceptible to damage from electrostatic discharge (ESD). When you see this icon, you must follow standard ESD guidelines to avoid damaging the equipment you are servicing.



Note: Notes either provide extra information about a topic or contain special instructions for handling a particular condition or set of circumstances.

Global Services and Support

Warranty Information

To understand the warranty for your Intermec product, visit the Intermec web site at www.intermec.com and click **Service & Support**. The Intermec Global Sales & Service page appears. From the Service & Support menu, move your pointer over **Support**, and then click **Warranty**.

Disclaimer of warranties: The sample code included in this document is presented for reference only. The code does not necessarily represent complete, tested programs. The code is provided “as is with all faults.” All warranties are expressly disclaimed, including the implied warranties of merchantability and fitness for a particular purpose.

Web Support

Visit the Intermec web site at www.intermec.com to download our current manuals in PDF format. To order printed versions of the Intermec manuals, contact your local Intermec representative or distributor.

Visit the Intermec technical knowledge base (Knowledge Central) at intermec.custhelp.com to review technical information or to request technical support for your Intermec product.

Telephone Support

These services are available from Intermec Technologies Corporation.

Services	Description	In the USA and Canada call 1-800-755-5505 and choose this option
Factory Repair and On-site Repair	Request a return authorization number for authorized service center repair, or request an on-site repair technician.	1
Technical Support	Get technical support on your Intermec product.	2
Service Contract Status	Inquire about an existing contract, renew a contract, or ask invoicing questions.	3

Services	Description	In the USA and Canada call 1-800-755-5505 and choose this option
Schedule Site Surveys or Installations	Schedule a site survey, or request a product or system installation.	4
Ordering Products	Talk to sales administration, place an order, or check the status of your order.	5

Outside the U.S.A. and Canada, contact your local Intermec representative. To search for your local representative, from the Intermec web site, click Contact.

Who Should Read This Manual

This *User's Guide* is for the person who is responsible for installing, configuring, and maintaining the EasyCoder PD41 Printer.

This *User's Guide* provides you with information about the features of the EasyCoder PD41, and how to install, configure, operate, maintain, and troubleshoot it.

Related Documents

This table contains a list of related Intermec documents and their part numbers.

Document Title	Part Number
<i>EasyCoder PD41 Quick Start Guide</i>	1-960655-XX
<i>Intermec Fingerprint v8.70.0/v10.0.0 Programmer's Reference Manual</i>	1-960582-07
<i>IPL Programmer's Reference Manual</i>	066396-013
<i>EasyCoder PD41 Safety Instructions</i>	1-960662-XX
<i>EasyLAN Software for PD41 Installation Instructions</i>	1-960667-XX
<i>EasyLAN User's Guide</i>	1-960590-03

The Intermec web site at www.intermec.com contains our documents (as PDF files) that you can download for free.

Before You Begin

To download documents

- 1** Visit the Intermec web site at www.intermec.com.
- 2** Click **Service & Support > Manuals**.
- 3** In the **Select a Product** field, choose the product whose documentation you want to download.

To order printed versions of the Intermec manuals, contact your local Intermec representative or distributor.



1 Getting Started

This chapter introduces the EasyCoder PD41, and explains how to get your new printer connected to your system and print a test label. The chapter covers the following topics:

- Description of the EasyCoder PD41
- Installing the Printer

Description of EasyCoder PD41

The EasyCoder PD41 printer is a dependable and versatile printer suitable for medium-duty applications in manufacturing, transportation and warehouse environments. It has all-metal chassis and covers, proven printing mechanics and powerful electronics providing sturdiness, performance and reliability.

The EasyCoder PD41 can print crisp variable-data labels continuously at 150 millimeters per second (mm/s) or 6 inches per second (ips). It takes industry standard 213mm (8.35 in) label rolls and 450 meters (18000 inches) of ribbon. The printer accepts a wide range of paper types with different thicknesses, as well as both ink-in and ink-out ribbon.

The EasyCoder PD41 offers versatile connectivity through serial and USB interfaces. It is also equipped with Parallel IEEE 1284 and / or EasyLan Ethernet interfaces depending on the chosen configuration.

The EasyCoder PD41 supports Intermec Fingerprint (FP v10.X.X) as well the Intermec Programming Language (IPL v10.X.X).

The printer is also designed to work with the Intermec Direct Protocol programming language (a slave protocol, subset of Fingerprint), the Intermec InterDriver and Intermec LabelShop. The InterDriver allows you to print labels from standard MS Windows applications, such as Microsoft Word. Intermec LabelShop is a series of label-design programs that work under MS Windows.

Other features, such as a cutter and an internal rewinder, are available as option kits.

Unpacking the Printer

Unpack the printer and its accessories on a flat surface such as a table.

Unpack the Printer

- 1 Open the box and lift out the printer and included accessories.

- 2** Check that no visible damage has occurred during transportation. Keep the packing material in case you need to move or reship the printer.
- 3** Check to make sure any options you ordered are included.
- 4** In addition to the options you may have ordered, the box should contain the following:
 - 1 – Intermec EasyCoder PD41 printer
 - 2 – One or more country-specific power cords
 - 3 – USB cable
 - 4 – Empty ribbon core for thermal transfer printing
 - 5 – High Media Edge Guide
 - 6 – Quick Start Guide
 - 7 – A PrinterCompanion CD containing software, this and other related manuals

If you find any damage has occurred during transportation, notify the carrier immediately. If the delivery is missing parts or is otherwise incorrect, report it to the distributor.

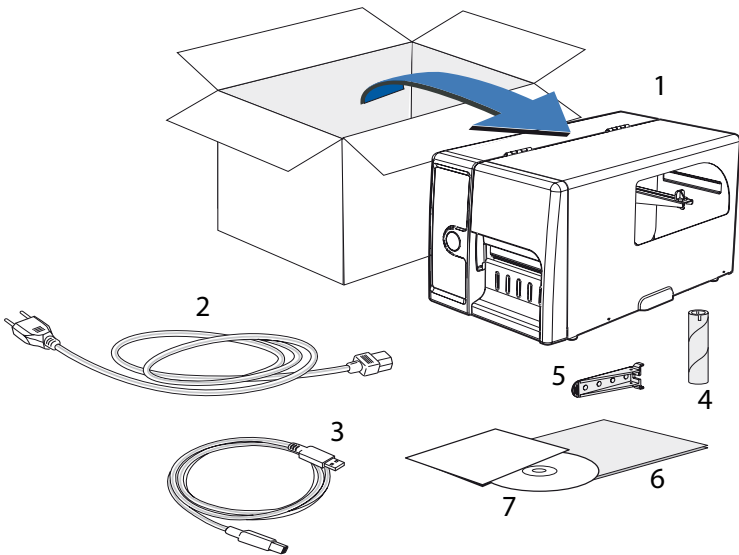



The discharge of electrostatic energy accumulated on the human body, clothing, or other surfaces can damage or destroy the printhead or electronic components used in this printer. Avoid touching the electrical connectors while unpacking and setting up the printer.

Product Identification

The machine and serial number labels are attached to the printer's rear plate, and contain information on type, model and serial number as well as AC voltage and frequency.

Front View

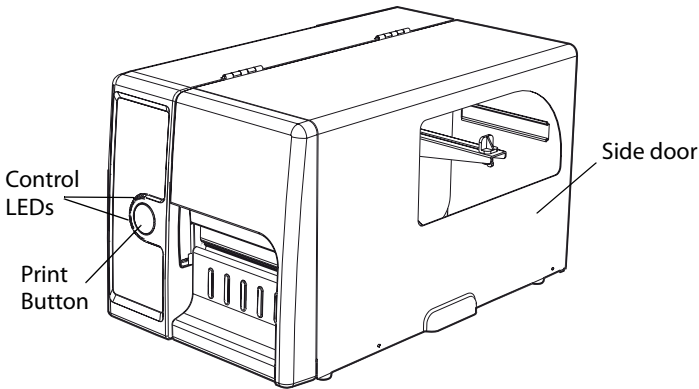

EasyCoder PD41: Front view



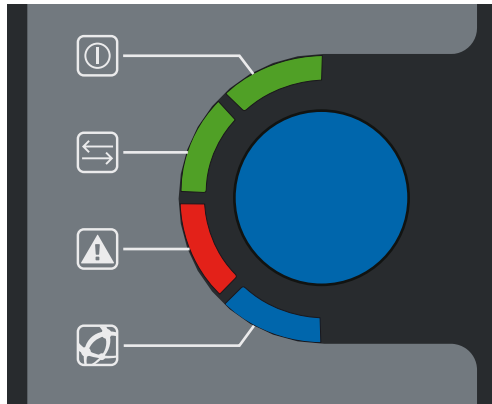

Controls and Indicators



Front panel: LEDs and the Print button.

The blue button on the front panel is the Print button, which also functions as a control button in Testmode. The significance of each of the four LEDs surrounding the Print button is described in the table below. A more complete description of the LEDs can be found in Chapter 2.

Control LEDs

LED name	Light Color	Symbol	Function
Power	Green		Power indicator.
Ready/Data	Green		Printer ready.
Error	Red		Error indicator.
Ready-to-Work™	Blue		Intermec Ready-to-Work™ indicator.

Rear View

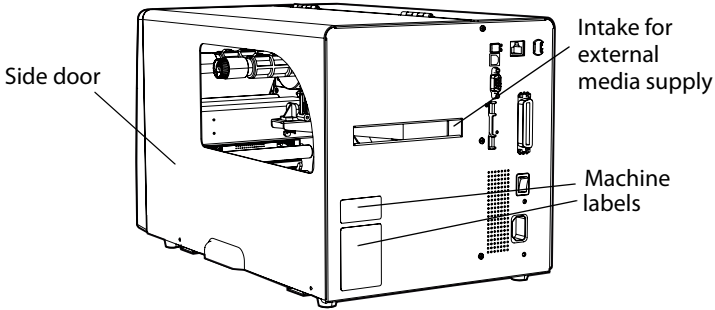

EasyCoder PD41: Rear View

Connectors

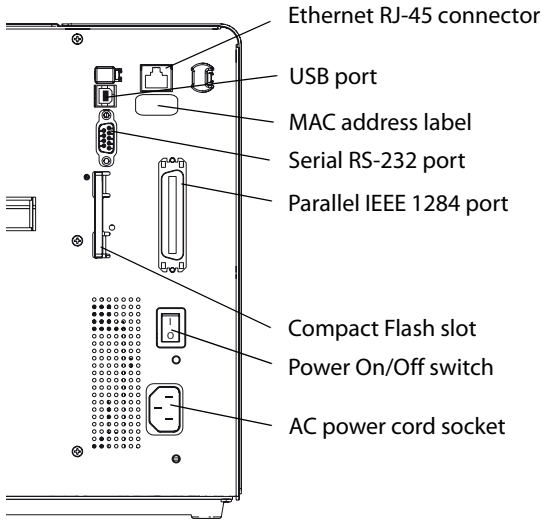

Rear view: Connection sockets

Media Compartment

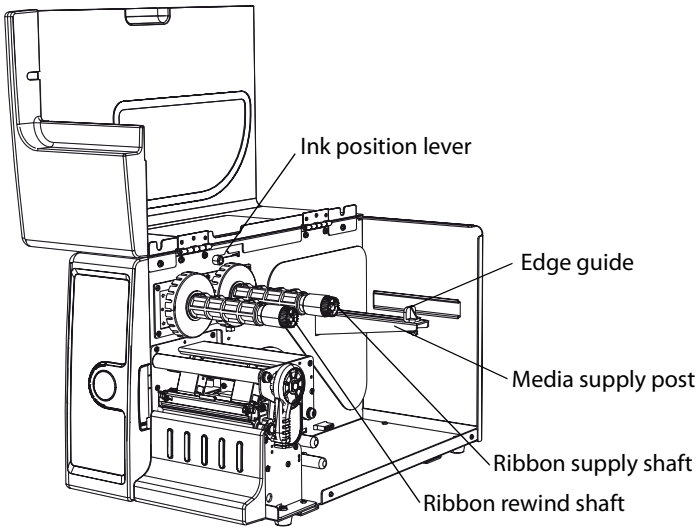

EasyCoder PD41: Media Compartment

Print Mechanism

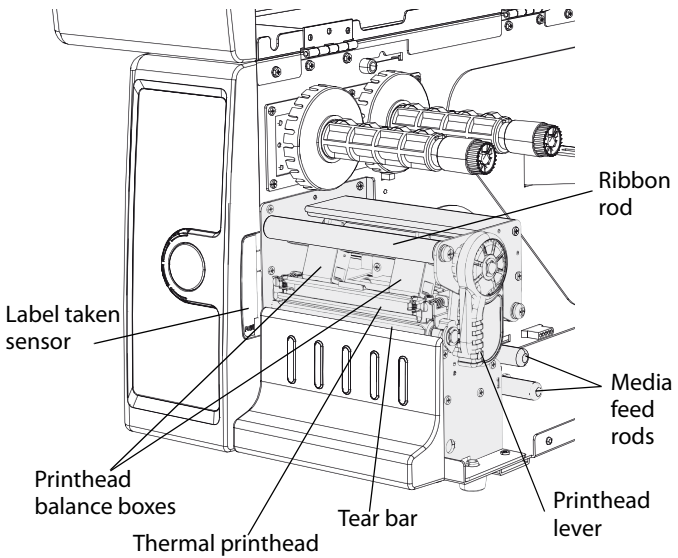

EasyCoder PD41: Print Mechanism

Installing the Printer

Plugging in the Printer

- 1 Make sure the Power Switch is turned off.
- 2 Connect the power cable to the printer.
- 3 Plug the power cable into your electrical outlet.

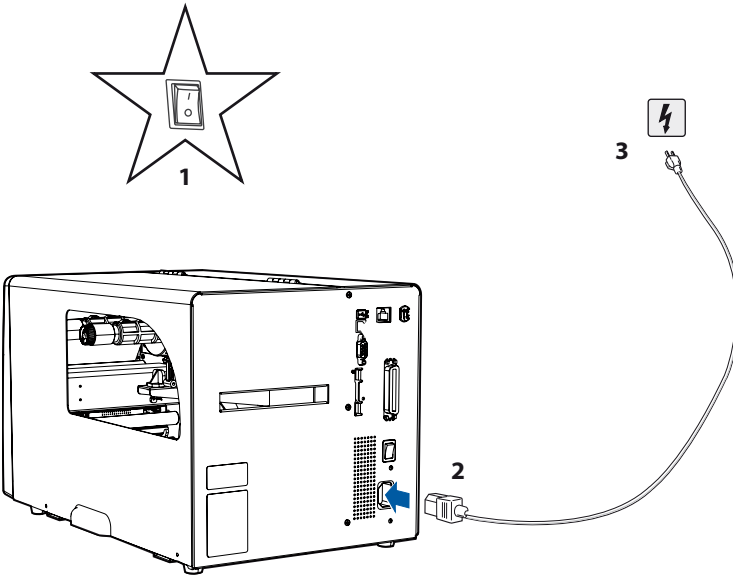

Installing the PD41: Stepwise instructions

Fingerprint and IPL

Your PD41 printer is equipped with Fingerprint or IPL (Intermec Programming Language) firmware. This affects the functionality of the printer and, to a certain extent, how you interact with it. In this manual you will come across information that applies exclusively to either firmware, so it is strongly recommended that you familiarize yourself enough with your PD41 to know whether it runs Fingerprint or IPL. The easiest way to do is to print a test label (see “Printing a Test Label” on page 10)

Connecting the Printer to your System

The EasyCoder PD41 is fitted with a USB Type B connector for the USB interface port and one 9-pin D-style subminiature (DB9) socket for the RS-232 serial interface port. In addition to this the printer is, depending on configuration, fitted with a 36-pin Centronics socket for the parallel (IEEE 1284) port and/or an RJ-45 socket for the Ethernet network connection. Information on the socket and connector types can be found in Appendix E, “Interfaces.”

Connecting the Printer through the USB interface

In order to use the USB connection, you need to install the Intermec InterDriver software on your computer. This can be found on the PrinterCompanion CD along with instructions on how to install it. The USB interface is not suitable for terminal connections and thus not for programming.

Connecting the Printer through the Serial Port

The serial connection can be used either with LabelShop or the Intermec InterDriver. It can also be used to directly send commands to the printer through a terminal connection, such as one established through the Windows HyperTerminal program. The printer’s default serial communication settings are: baud rate 9600, 8 data bits, no parity, 1 stop bit and no flow control. See Appendix C, “Setup parameters,” for more information.

Connecting the Printer to a Network

The printer is set to automatically receive an IP number from the network (DHCP). The network connection can be used either with LabelShop or the Intermec InterDriver. It can also be used to directly send commands to the printer through a terminal connection, such as one established through the Windows HyperTerminal program. In this case, it utilizes the Raw TCP protocol through port 9100.

How to Connect the PD41 to Your Network

- 1 Plug a connected Ethernet cable into the Ethernet port in the rear of the printer.
- 2 Turn the printer on. Wait for the blue Ready-to-Work LED to stop blinking. A steady light indicates that the printer has been successfully connected to the network.

- 3 Turn the printer off. Print a test label to find out which IP number has been assigned to the printer (see the next section for information on how to print test labels).
- 4 Enter the printer's IP number in the address field of your web browser (for example `http://255.255.255.001`). This brings up the printer's home page, where it is possible to check and modify various printer settings. Modifying settings requires a login and a password: by default, these are set to "admin" and "pass" respectively.

Please refer to the *EasyLAN Software for PD41 Installation Instructions* document and the *EasyLAN User's Guide* for more information on how to set up and operate the PD41 in your network environment.

If your network does not assign IP numbers automatically, or the Ready-to-Work indicator is flashing to indicate a network error, you can use PrintSet 4 (found on the PrinterCompanion CD) to correct the network settings. Alternatively, set up a terminal connection through the serial interface and use the Fingerprint `SETUP` command. See "Changing Configuration Settings" on page 44, or refer to the *Intermec Fingerprint v10.X.X Programmer's Reference Manual*. IPL users should turn to the *EasyLAN Software for PD41 Installation Instructions* for information on how to manually configure the network connection.

Connecting the Printer through the Parallel Port

Use the parallel interface (also referred to as "centronics"), with Intermec LabelShop or the Intermec InterDriver. The parallel port supports Windows plug-n-play and additional status reporting through IEEE 1284 nibble ID mode. Cable is not included.

Printing a Test Label



In order to verify that the printer is fully functional and to obtain its current configuration, you can print a test label. This procedure is part of the Testmode function, described in full in Chapter 5.

Printing test labels

- 1 Make sure the printer is turned off.

- 2 Load media as described in Chapter 2, “Loading Media”.
- 3 Press and hold down the blue Print button.
- 4 Keep the Print button pressed down, and turn on the power switch. After about ten seconds the printer enters Testmode and three of the front LEDs start flashing one at a time.
- 5 Release the Print button at the appropriate time to establish the media settings. Each of the LEDs (except the Power LED) represent a media type according to the following table:

Setting the Paper Type

Flashing LED determines			Media Type
Data/Ready	Green		Labels with gap
Error	Red		Tickets with black mark
Ready-to-Work	Blue		Continuous stock

The printer will print several test labels containing the printer's setup parameters. It will then enter Dumpmode.

- 6 Press the Print button once to exit Dumpmode.



2 Operating the Printer

This chapter explains the basic operation of the printer. You will learn how to load media for different types of operation and familiarize yourself with the printer's control LEDs and the Print button. This chapter covers the following topics:

- Loading Media
- LED indicators and the Print button

Loading Media

The EasyCoder PD41 can print on labels, tickets, tags and continuous stock in various formats.

Tear-Off (straight-through) Operation

This section describes the case when media is torn off manually against the printer's tear bar. This method is also known as "straight-through" printing. Different sorts of media can be used in Tear-Off operation:

- Non-adhesive continuous stock
- Self-adhesive continuous stock with liner
- Self-adhesive labels with liner
- Tickets with gaps, with or without perforations
- Tickets with black marks, with or without perforations

Tear-Off

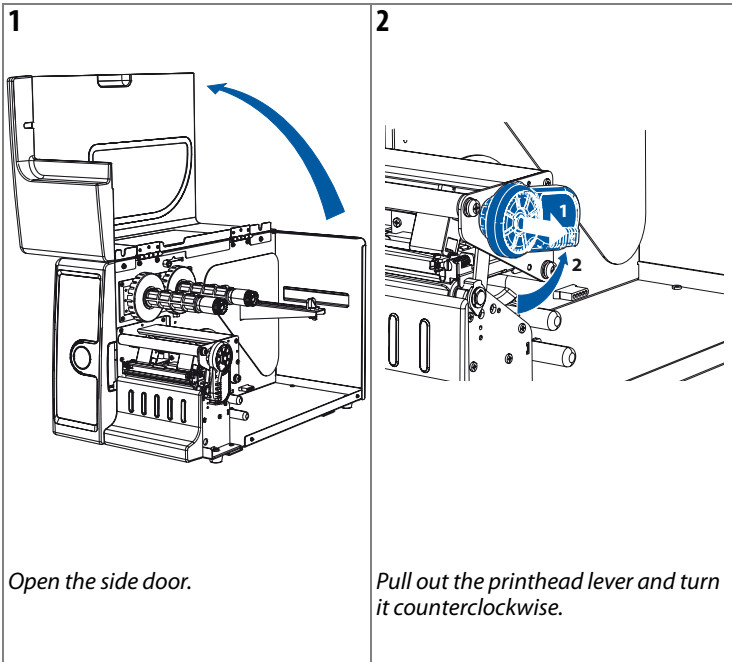

Tear-Off, continued

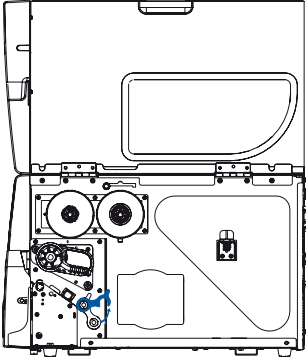
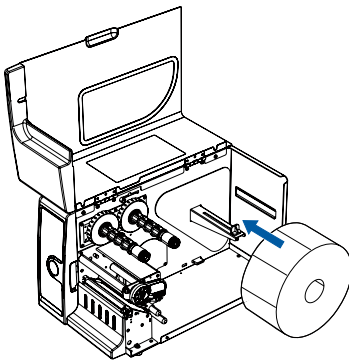
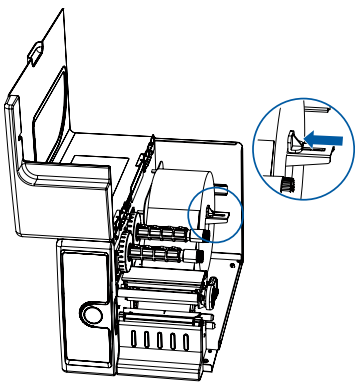
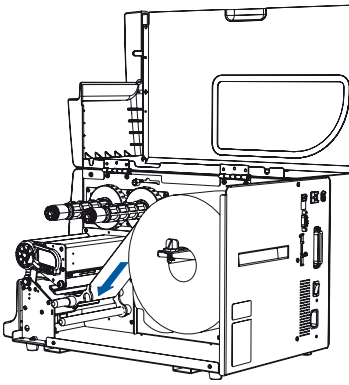
<p>3</p>  <p><i>Lift the label feed guide.</i></p>	<p>4</p>  <p><i>Load a media roll onto the media supply hub, pushing it all the way in.</i></p>
<p>5</p>  <p><i>Lock the position of the media roll with the media edge guide.</i></p>	<p>6</p>  <p><i>Guide the media through the rods.</i></p>

Tear-Off, continued

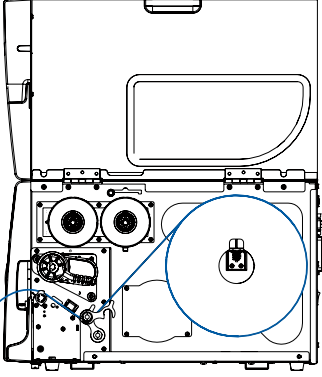
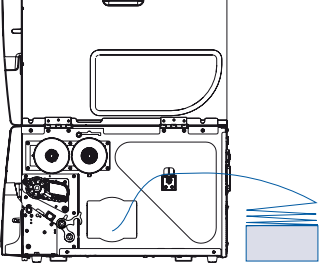
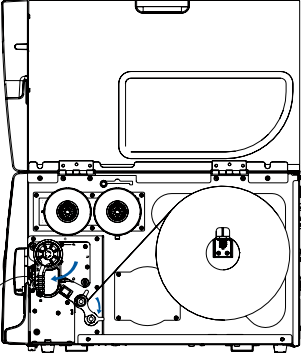
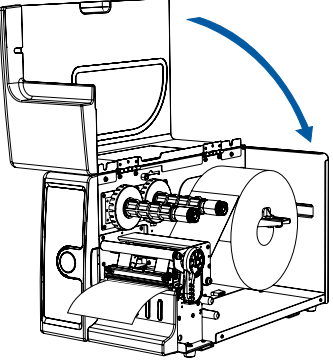
<p>7</p>  <p>Route the media through the print mechanism.</p>	<p>8</p>  <p>If using fan-fold media, load it through the rear intake and route the media the same way as a media roll.</p>
<p>9</p>  <p>Reset the label feed guide and the printhead lever.</p>	<p>10</p>  <p>Close the side door. Press the Print button to advance the media.</p>

Peel-Off (Self-Strip) Operation

This section describes the case when self-adhesive labels are separated from the liner immediately after printing. The same procedure is followed when installing media for Batch Takeup, with the difference that both label and liner is rewound, and the label-taken sensor is not used. These modes of operation require an optional internal rewinder unit, see Appendix F, “Options.” This is also known as self-strip operation. The label-taken sensor can hold the printing of the next label in a batch until the present label has been removed. Only self-adhesive labels with liner can be used in peel-off operation.

Peel-Off

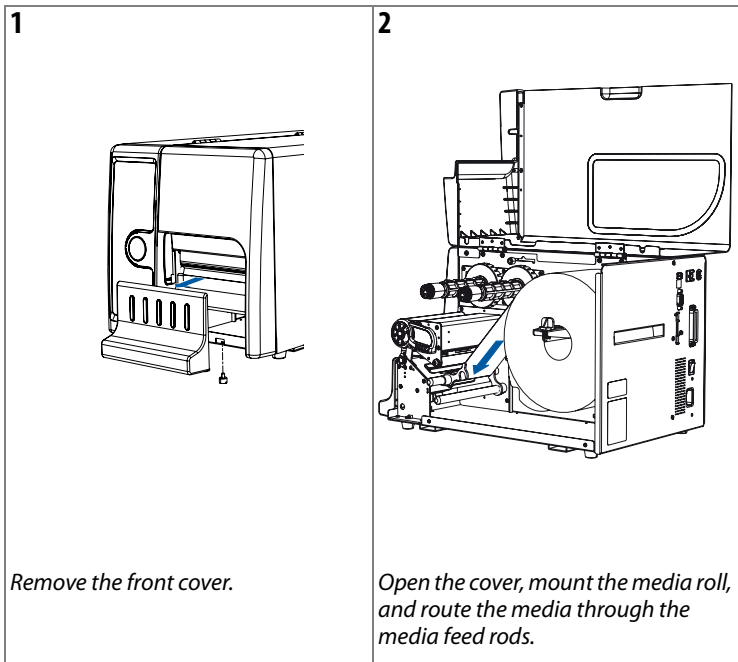

Peel-Off, continued

3

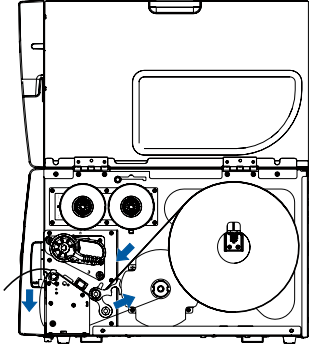

Route the liner through the print mechanism and back as shown above.

4

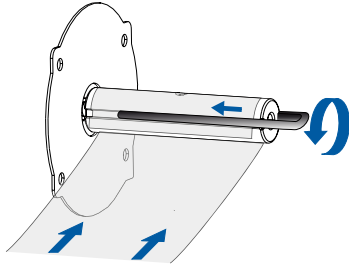

Wrap the liner on the liner takeup roll and lock it in place.

5

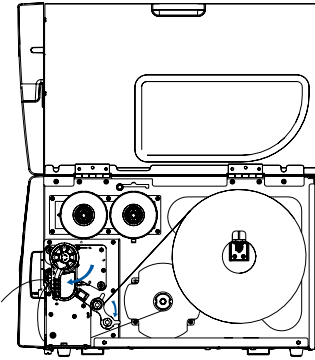

Reset the label feed guide and the printhead lever.

6

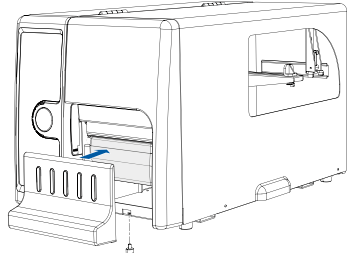

Reattach the front cover.

Peel-Off, continued

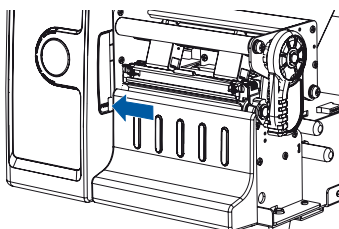
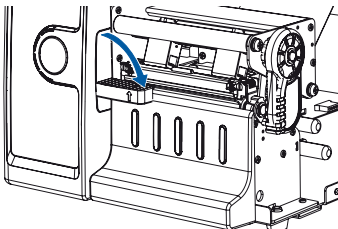
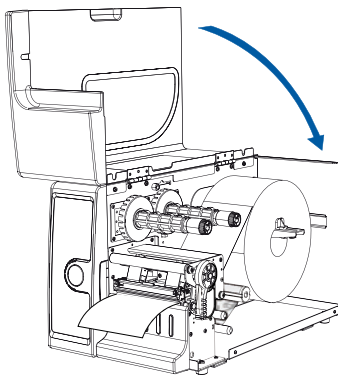
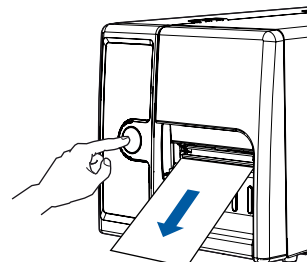
<p>7</p>  <p><i>Push in the location indicated above to bring out the label-taken sensor.</i></p>	<p>8</p>  <p><i>Turn the Label-Taken Sensor (LTS) to a fully horizontal position.</i></p>
<p>9</p>  <p><i>Close the side door.</i></p>	<p>10</p>  <p><i>Press the Print button to feed the media.</i></p>

Loading Thermal Transfer Ribbon

Thermal transfer printing makes it possible to use a wide range of receiving face materials and gives a durable printout that is less vulnerable to fat, chemicals, heat, sunlight etc. than direct thermal printing. Make sure to select a ribbon type that matches the type of receiving material and set up the printer accordingly.

The EasyCoder PD41 can use transfer ribbon rolls wound with the ink-coated side facing either outward or inward.

The ribbon is normally loaded in conjunction with a new media roll. For clarity, however, the illustrations below do not show the media roll. See the previous sections for information on how to load media for your type of operation.

Loading Ribbon

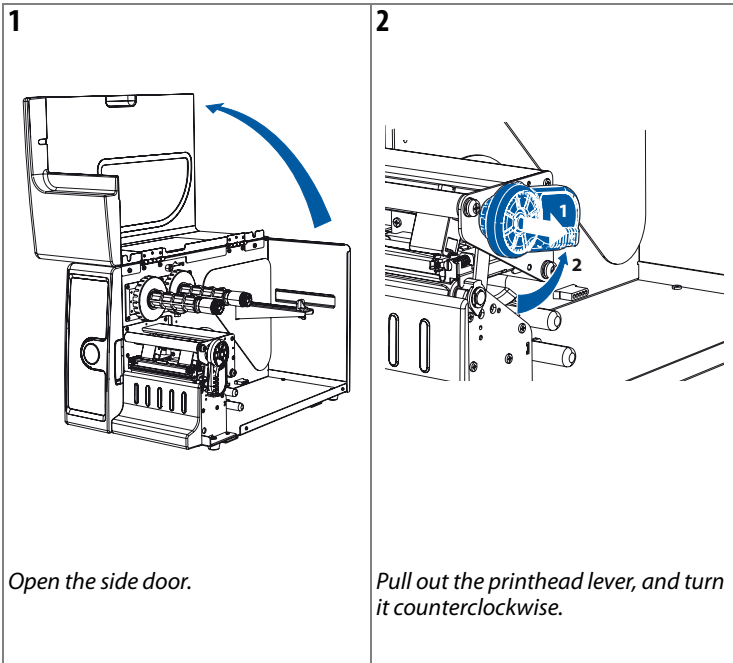

Loading Ribbon, continued

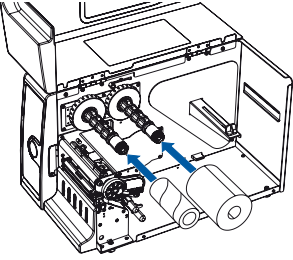
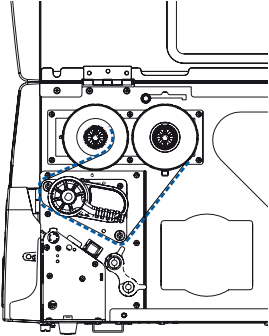
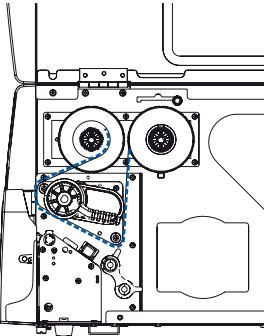
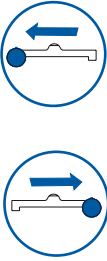
<p>3</p>  <p><i>Push the ribbon roll onto the right ribbon hub, and the empty ribbon core on the left hub.</i></p>	<p>4a</p>  <p><i>In case you are using ink-out ribbon, route the ribbon as shown here.</i></p>
<p>4b</p>  <p><i>In case you are using ink-in ribbon, route the ribbon as shown in this figure.</i></p>	<p>5</p>  <p><i>Move the ink-position lever to the left for ink-out ribbon, and to the right for ink-in ribbon.</i></p>

Loading Ribbon, continued

6

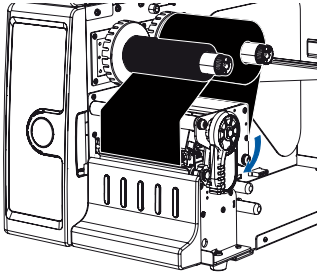

Reset the printhead lever to its original position. Close the side door.

LED indicators and the Print Button

The PD41 printer can enter the following different “states”, which in turn indicate its current mode of operation.

PD41 Printer States

State	Explanation
Power Off	
Upgrading	Firmware is being upgraded.
TestMode	See Chapter 5 for description.
Extended TestMode	See Chapter 5 for description.
PUP	Power-UP (starting up)
Idle	
Application running	Fingerprint only.
Printing	
Printing (wait for LTS)	Waiting for Label Taken Sensor to indicate that label has been taken.
Paused	Paused during print job
Error	Error state

LED indicators

The four LED indicators will be turned on, off or flash depending on which state the printer is in. The Power LED will always be lit for all states except Power Off.

The blue Ready-to-Work LED shows the operational status of the printer. In simple terms, it is lit when the printer is operational. When the Ready-to-Work indicator is turned off, or flashes, it indicates that the printer is not fully operational. There are a number of conditions that can cause this behaviour; refer to Chapter 4, “Troubleshooting” for a detailed explanation. It can also flash when in Testmode or Extended Testmode, see “Running Testmode” in Chapter 5.

The red Error LED will be lit or flash when an error condition has occurred. This will also cause the Ready-to-Work LED to flash or turn off.

The green Ready/Data indicator will be turned on, off or flash depending on the printer's current state. The behavior of the green Data/Ready and red Error LEDs is shown in the table below.

Ready/Data and Error LED behavior

State	Ready/Data	Error
Power Off	Off	Off
Upgrading	LEDs turned on one after the other.	
Testmode	See Chapter 5 for description.	
Extended Testmode	See Chapter 5 for description.	
PUP	On	Off
Idle	On/Flash ¹	Off
Application running	On	Off
Printing	On/Flash ¹	Off
Printing (wait for LTS)	Quick flashes ²	Off
Paused	Flash ³	Off
Error	Off	On / Flash ⁴

Footnotes on flashing LED behavior:

- 1 Flashing with 50% duty cycle, 0.8 second period when receiving data, synchronized with Ready-to-Work LED.
- 2 Two fast flashes, 1.6 second period.
- 3 Flashing with 50% duty cycle, 0.8 second period, not synchronized with Ready-to-Work LED.
- 4 Error LED will be lit for Out of Paper, Out of Ribbon, Head Lifted, Cutter Error and Testfeed not Done conditions. Will flash as (2), when thermal printhead is too hot. Will flash as (3) for other error conditions caught by the Direct Protocol error handler.

Print Button

The Print button has different functionality depending on the printer's state. Different actions can be specified by pressing the button less than and more than one second respectively.

Print Button function

State	Button pressed < 1 s	Button pressed > 1 s	“Double- click”
Power Off	No action		
Upgrading	No action		
Testmode	See “Running Testmode” in Chapter 5		
Extended Testmode	See “Running Testmode” in Chapter 5		
Idle (FP)	Formfeed/ Printfeed	Testfeed	
Idle (IPL)	Formfeed	Continuous feed while button is pressed	Enter Pause mode
Application running	Defined by application		
Printing	Pause print job		
Paused (FP)	Continue print job	Cancel print job	
Paused (IPL)	Continue print job		
Error	See Chapter 4, “Troubleshooting”		



3 Maintaining the Printer

This chapter explains basic maintenance of the printer. By following the instructions in this chapter you avoid common problems, and increase the lifetime of your printer. This chapter covers the following topics:

- General Maintenance Advice
- Printhead Cleaning
- Internal Cleaning
- External Cleaning

General Maintenance Advice

In order to attain optimal productivity and a long life for your EasyCoder PD41, it is recommended that you regularly inspect the printer and its operation environment to ensure the printer is operated correctly.

Read the *EasyCoder PD41 Safety Instructions* for basic operational safety requirements. Keep the printer in a dry area, away from larger electrical motors, welders and similar which might affect printer operation.

Clean you printer regularly, as described in the procedures below, in order to maintain the quality of your labels and extend the life of your printer.



Warning

Always unplug the power cord before cleaning the printer.

Printhead Cleaning

Cleaning the printhead on a regular basis is important for the life of the printhead and to maintain high printout quality. You should clean the printhead using cleaning cards or a cotton swab moistened with isopropyl alcohol, preferably each time you load a new supply of transfer ribbon.



Warning

Isopropyl alcohol [(CH₃)₂CHOH] is a highly flammable, moderately toxic, and mildly irritating substance.

Cleaning the printhead

- 1 Open the side door.
- 2 Remove the media and ribbon.
- 3 Pull out the printhead lever and flip it counterclockwise a quarter of turn.

- 4 Use a cleaning card or a soft cotton swab moistened with isopropyl alcohol to dissolve any contamination on the line of heat-emitting dots at the front/bottom of the printhead.
- 5 Wait 30 seconds and carefully rub off any contamination. Repeat if necessary.



Caution

Never use any hard or sharp tools to peel away stuck labels or similar. The printhead is delicate and can easily be damaged.

- 6 Allow the printhead to dry for a minute or more before loading a new supply of media and ribbon.

Internal Cleaning

Regular cleaning of the printer's media compartment ensures smoother printing operation and avoids problems with media jams.

Use a soft cloth moistened with isopropyl alcohol to clean the inside of the printer. Be sure to keep the following parts clean:

- Drive roller and tear bar.
- Media edge guides and media path.
- Label sensors.



Warning

Isopropyl alcohol [(CH₃)₂CHOH;CAS67-63-0] is a highly flammable, moderately toxic, and mildly irritating substance.

If there are stuck labels, or adhesive residue from labels, peel as much as possible with your fingers, and then use isopropyl alcohol to dissolve the remaining adhesive.

External Cleaning

Making sure to keep the printer clean externally will reduce the risk of dust or foreign particles reaching the inside of the printer and affect printer functionality.

Chapter 3 — Maintaining the Printer

Use a soft cloth, possibly moistened with water or a mild detergent when cleaning the printer externally. Make sure to keep the surface surrounding the printer clean as well.



Warning

If the printer is used in an environment where the premises are cleaned by a water hose or steam, move the printer to another room or cover it very carefully with a plastic sheet and make sure that the power cord is unplugged.



4 Troubleshooting

This chapter helps to diagnose problems that may occur during printer operation and how to resolve them. This chapter covers the following topics:

- Printer Operation Problems
- Print Quality Problems
- Troubleshooting Adjustments

Printer Operation Problems

The following table lists possible problems that affect the printer's operation.

Printing Operation Problems

Problem	Solution / Reason
The Power control LED is not lit when power is switched on.	<ul style="list-style-type: none">• Check that the power cable is correctly connected to printer and electrical outlet.
Error LED turns solid red after printing.	<ul style="list-style-type: none">• Check if printer is out of media or ribbon.• Check if media is jammed or tangled.• Check that the print mechanism is locked and closed correctly.• Check the cutter.• Check application.
Label is jammed after printing.	<ul style="list-style-type: none">• Clear the media jam. If the label is stuck on the thermal printhead, clean as instructed in Chapter 3.
When printing, labels are skipped.	<ul style="list-style-type: none">• Run a new testfeed by holding print button more than one second.• Check if label gap sensor is disturbed by dust or foreign particles.
When using cutter, label was not cut straight.	<ul style="list-style-type: none">• Check whether the media thickness exceeds 0.25mm (9.8 mils).• Check if the media is loaded correctly.
When using cutter, label could not feed or abnormal cutting occurs.	<ul style="list-style-type: none">• Check that the cutter is installed properly.• Check if paper feed rods are sticky. Clean as described in Chapter 3.
Blue Ready-to-Work LED blinks.	<ul style="list-style-type: none">• See section later in this chapter regarding the Ready-to-Work LED.
When using internal rewinder, abnormal function occurs.	<ul style="list-style-type: none">• Check that media is loaded correctly.
Printer keeps printing or feeding when it should stop.	<ul style="list-style-type: none">• Check media settings.• Check label gap sensor position.• Sensors may be dirty.
Printing is slow.	<ul style="list-style-type: none">• Check application.

Print Quality Problems

Print Quality Problems

Problem	Solution / Reason
Printout is faded or weak	<ul style="list-style-type: none"> • Fingerprint users: Check the media settings: Constant, Factor and Contrast. • IPL users: Check the Sensitivity setting. • Check if printhead needs cleaning. • Check printhead pressure. • Check printhead dotline position.
Printer is working but nothing is printed	<ul style="list-style-type: none"> • Check if media is placed upside down. • Ensure that the ink-side of the ribbon faces the media. • Select the correct media type, direct thermal or thermal transfer printing. • Check that the printhead is correctly connected to the print mechanism.
Only partial labels are printed	<ul style="list-style-type: none"> • Check printhead balance. See later in this chapter.
Part of the images is not printed along the feed direction	<ul style="list-style-type: none"> • Check if printhead needs cleaning. • Check that the ribbon does not wrinkle, and follow instructions on ribbon adjustments in this chapter.
Printout darkness is uneven across media path	<ul style="list-style-type: none"> • Check printhead balance. • Check printhead pressure.
Printout is not in desired position	<ul style="list-style-type: none"> • Check for errors in printing software application. • Check if label gap sensor is disturbed by media, dust or ribbon. • Check the lateral position of label gap sensor. • Check the edge guide and media guide. • Check the media (insufficient transparency, interfering preprint lines in black mark operation, etc.) • Check if platen roller needs cleaning or replacement.

Ready-to-Work™ Indicator

The blue Ready-to-Work LED is lit when the printer is operational. It can be turned off or flash in case something is not working as expected.

Ready-to-Work LED Flashing or Off

The Ready-to-Work indicator is set to flash when the printer is receiving data, as well as under several different error conditions. Normally, this is due to an IP link error, where the printer has a network card but has not yet received an IP number. Other causes may be that the printhead is lifted, or the media is loaded incorrectly. The Ready-to-Work LED will be turned off if the printhead temperature is too high. Fingerprint users can obtain an error diagnosis with the command `SYSHEALTH$`. Enter the line `PRINT SYSHEALTH$` through a terminal connection to receive the printer's Ready-to-Work status.

Troubleshooting Adjustments

This section describes in detail some of the solutions mentioned in the Troubleshooting tables above.

Ribbon Wrinkling Adjustments

The following two procedures can solve ribbon wrinkling problems.

Ribbon Tension Adjustment

- 1 Push the knob on the ribbon supply hub.
- 2 Rotate it clockwise to increase breaking force or counterclockwise to decrease breaking force.

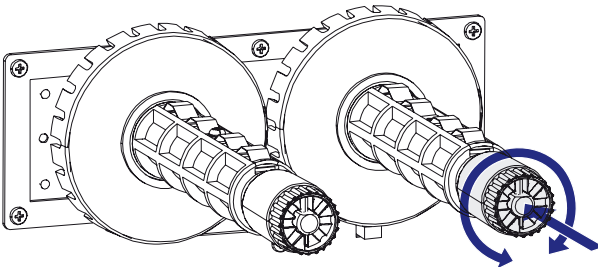

Ribbon tension adjustment

Ribbon Shield Adjustment

The ribbon shield mechanism is located on the thermal printhead. It has two adjustable screws, A and B, as shown below.

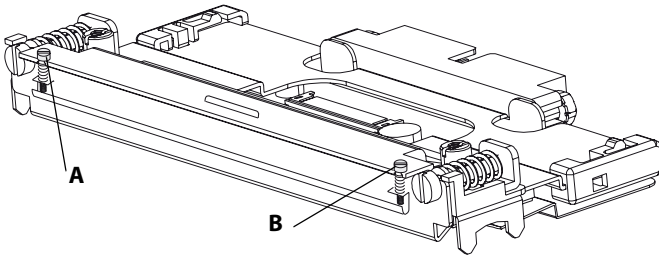

Ribbon shield adjustment screws

If the label printout matches Test label A, turn screw A clockwise. If the printout matches Test label B, turn screw B clockwise. Turn the screw half a circle and perform a new test printing. Continue until you achieve a smooth printout quality. Screw adjustment must not exceed two full turns or paper may not feed smoothly. In such a case, turn the screws counterclockwise completely and start over the adjustment.



Possible printouts due to ribbon wrinkling

Clearing Media Jams

Clearing Media Jam in Print mechanism

- 1 Switch off the power to the printer.
- 2 Pull the printhead lever out and turn it counterclockwise to lift the printhead.
- 3 Pull out the media from the print mechanism.

If the media has been wound up or is stuck on the platen roller, carefully remove it by hand without using any sharp

tools that can damage the platen roller or printhead. Avoid rotating the platen roller.



Take care to avoid causing the platen roller to rotate. The electronic components may be damaged permanently.

- 4 Cut off any damaged or wrinkled part of the media.
- 5 Check to see if there is any adhesive somewhere in the print mechanism. If so, follow the cleaning instructions in the section “Internal Cleaning” in Chapter 3.
- 6 Reload the media as described in Chapter 2.
- 7 Switch on the power.
- 8 Readjust the media feed by pressing the Print button.

Printhead Adjustments

A correctly adjusted printhead is crucial for obtaining optimal printout quality.

Adjusting Printhead Balance

The printer is factory-adjusted for full-size media width. When using media less than full-width, it is recommended that you adjust the position of the printhead balance boxes in order for the printhead to be equally pressured against full media width. Printhead balance might be poorly adjusted if the printout is weaker on one side of the media path.

To adjust the printhead pressure, follow these steps:

- 1 Open the side door.
- 2 If transfer ribbon has been installed, remove it.
- 3 Lift the printhead by pulling the printhead lever out and flipping it a quarter of a turn counterclockwise.
- 4 Move the balance box on the right side (outer) top the right (outward) for wider media, and inwards (to the left) for narrower media.

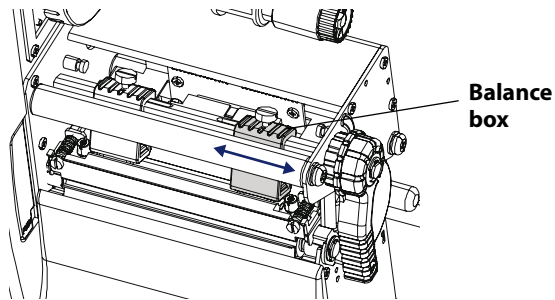

- 5 Engage the printhead and load the ribbon.
- 6 Test and readjust if necessary. (Tip: Use direct thermal media to avoid loading and unloading of ribbon multiple times.)

Adjusting Printhead Pressure

The pressure of the thermal printhead against the platen roller is factory-adjusted. However, if the printing is weaker on one side of the media, or if the thermal transfer ribbon starts to crease (indicated by unprinted white streaks along the media feed direction), it may be necessary to readjust the printhead pressure.



Note: Before readjusting the printhead pressure, try to move the outer balance box as described in Adjusting Printhead Balance procedure.

- 1 Open the side door.
- 2 Remove the ribbon.
- 3 Lift the printhead by pulling the printhead lever out and flipping it a quarter of a turn counterclockwise.
- 4 Use a straight-slot screwdriver to turn the screw at the top of the balance boxes clockwise to increase the pressure, or counterclockwise to decrease the pressure.

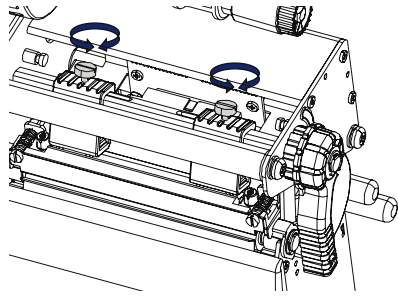

- 5 Engage the printhead and load the ribbon.
- 6 Test and readjust if necessary. (Tip: Use direct thermal media to avoid loading and unloading of ribbon multiple times.)

Adjusting Printhead Dot Line

When using thick or stiff media, the printhead needs to be moved forward so the dot line is aligned precisely with the top of the platen roller. They must of course be perfectly parallel as well.

- 1 Open the side door.
- 2 Remove the ribbon and engage the printhead.
- 3 Use a straight-slot screwdriver to turn the two screws at the top of the printhead bracket counterclockwise a single turn.

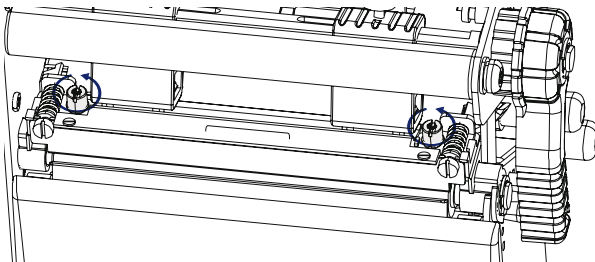

- 4 Lift the printhead by pulling the printhead lever and flipping it counterclockwise a quarter of a turn.
- 5 Carefully turn both screws at the front of the printhead clockwise **a quarter of a turn** at a time (a full turn corresponds to 0.55 mm, which is a lot). Make sure to make identical adjustments on both screws. If you are unsure,

tighten both screws completely by turning them counterclockwise as far as they go and start over.

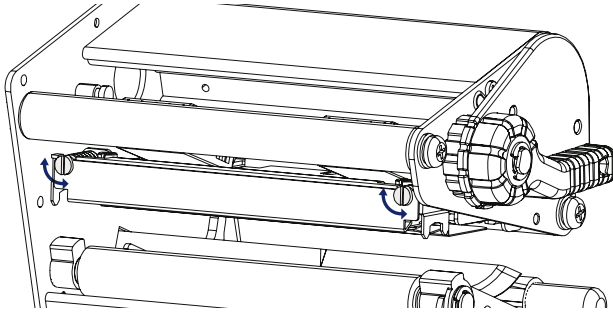

- 6** Engage the printhead and lock the printhead by tightening the two screws at the top of the printhead bracket, that is, the reverse action of step 3.
- 7** Load the ribbon (if any).
- 8** Test and readjust if necessary. (Tip: Use direct thermal media to avoid loading and unloading of ribbon multiple times.)

Label Gap Sensor Adjustments

The label gap/black mark sensor (also called Label Stop Sensor - LSS) is a photoelectric sensor that controls the printer's media feed by detecting gaps between labels, or slots or black marks in continuous stock. This requires the label gap sensor to be aligned with the gaps, slots or marks on the media. If you are using irregularly shaped labels, align the sensor with the front tip of the labels.

Adjusting Label Gap Sensor Position

- 1** Use the lever at the rear side of the print mechanism to move the sensor inward or outward.

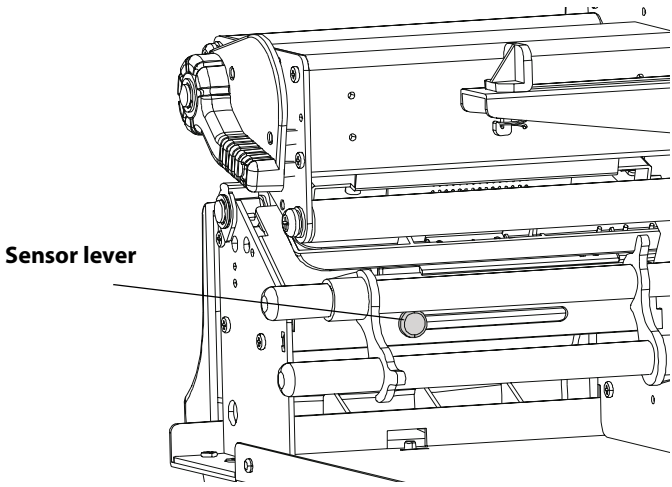

- 2 Check the point of detection from the front (with the printhead lifted.)

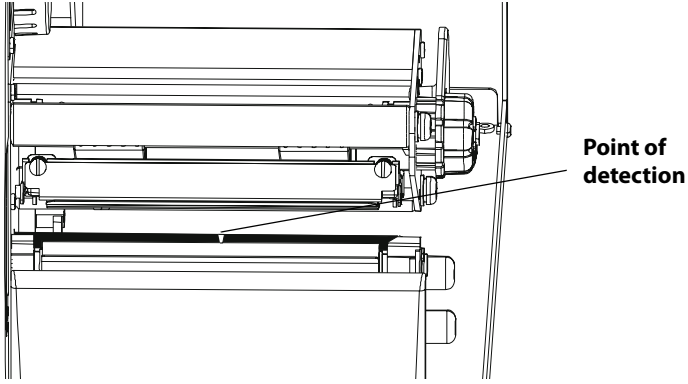



5 Setting up the Printer

The EasyCoder PD41 has many settings that control printer operation, communication settings, media types and more. This chapter describes the printer's startup sequence and explains how to set or change setup parameters. It also includes a description of the two Testmodes available, and a guide on firmware upgrading. This chapter contains the following sections:

- The Printer Startup Sequence
- Changing Configuration Settings
- Running Testmode
- Upgrading Firmware

The Printer Startup Sequence

When switched on, the printer will go through a sequence of steps in order to decide what settings should be set and what application (if any) should be started. Users that run Fingerprint firmware on their PD41 are given more options and more control over the printer's startup behaviour.

Printer Startup Sequence (Fingerprint)

- 1 Check for firmware binary on CompactFlash card. If so, upgrade.



Note: If the CompactFlash contains an earlier firmware version than one installed in the printer, the printer's firmware will be downgraded.

- 2 Check if printhead is lifted and button is pressed. If so, go to Extended Testmode, otherwise continue startup with step 3.
- 3 Check for the presence of a startup file (AUTOEXEC.BAT), first on CompactFlash, then on "c/". If so, run the startup file.
- 4 Check to see if button is pressed. If so, go to Testmode.
- 5 Continue Power-Up. Check APPLICATION file in "c/:" for program file name. If found, run. If empty, go to idle state.

Users can thus control the printer's behavior after startup by creating an autoexec.bat file and saving it on a memory card or in the printer's permanent memory (device "c/"), writing an application name in the "APPLICATION" name, or choosing to go into Testmode.

It is recommended to start custom applications by writing the name of the desired program ("ProgramName.PRG") in the APPLICATION file in "c/". See the *Intermec Fingerprint v10.0.0 Programmer's Reference Manual* to learn how to edit and save a file to the printer.

Starting a custom application can also be done by creating a startup file (autoexec.bat) which will execute on startup. This file must contain Fingerprint commands that are interpreted immediately. Normal commands are LOAD and RUN. See the *Intermec Fingerprint v10.0.0 Programmer's Reference Manual* to learn how to create and save such a file to the printer.

Printer Startup Sequence (IPL)

- 1 Check for firmware binary on CompactFlash card. If so, upgrade.



Note: If the CompactFlash contains an earlier firmware version than one installed in the printer, the printer's firmware will be downgraded.

- 2 Check if printhead is lifted and button is pressed. If so, go to Extended Testmode, otherwise continue startup with step 3.
- 3 Check to see if button is pressed. If so, go to Testmode.
- 4 Continue Power-Up. Run a testfeed.

The process of entering and using Testmode and Extended Testmode is described later in this chapter.

Changing Configuration Settings

The complete list of setup options can be found in Appendix C. Depending on the communication method you use with your printer, you can set configuration settings with different methods.

Using PrintSet 4

The recommended way to set your printer's configuration is to use the included PrintSet 4 program. PrintSet 4 can communicate with your printer either via a serial cable or a network connection. You will find PrintSet 4 on the Printer Companion CD, and on the Intermec website. This printer configuration program works on computers equipped with Windows 98 and up, and allows you to easily change all of the setup parameters. It also includes setup wizards, which guide you through common configuration tasks.

Using the Printer's Home Page

If you have a network option and the printer is available on the network, you can browse to the printer's home page: Just enter the printer's IP number in your browser's address field. There you can enter the configuration page and change the settings. You will need the printer's administrator username and password.

Using the Command Line

You can change setup parameters by sending commands directly through your terminal program (either through serial or network connection). The Fingerprint command to use is `SETUP`, and should be followed by the node and its values you want to set. For example:

```
SETUP "MEDIA,MEDIA TYPE,LABEL (w GAPS)"
```

On printers running IPL, the same effect is attained by executing the following string of commands:

```
<STX><SI>T1<ETX>
```



Note: IPL users should first verify that they have the correct hyperterminal settings. See the screenshot on the next page.

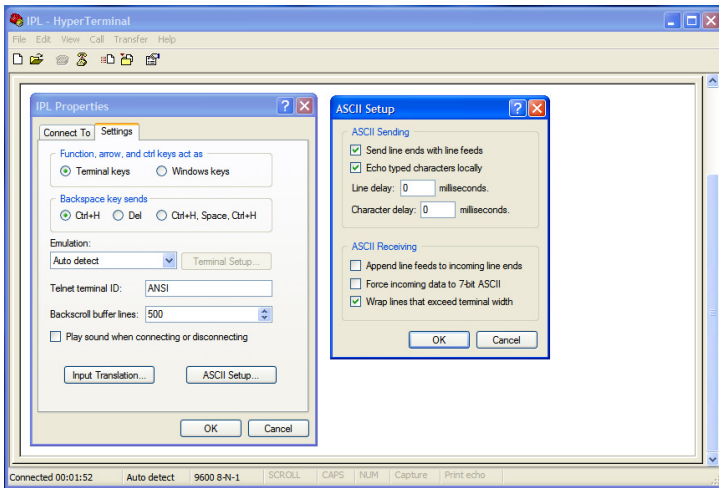

Hyperterminal settings (IPL only)

For more information on how to change setup parameters, see the *Fingerprint v10.X.X Programmer's Reference Manual*, or the *IPL Programmer's Reference Manual*.

Running Testmode

You can check certain settings, print a test label, or enter the dump mode for troubleshooting purposes by using the printer testmodes. Two testmodes are available, Testmode and Extended Testmode.

Testmode

Normal testmode is used to select the media type, to print test labels, and to enter dump mode. Testmode is entered by pressing the Print button while switching the printer's power on. This starts the Testmode which will go through a sequence of actions; these can be controlled by pressing the Print button at the cue of different LED flash patterns. The sequence of steps in testmode is shown in the tables below:

Testmode: Activating

Data/ Step	Ready	Error	RtW	Button	Comment
1				1	Make sure the printhead lever is lowered. Press and hold the Print button and switch the printer On. Testmode is activated after 10 seconds.
2	1	1	1		LEDs flash fast one at a time. Keep button pressed.

Testmode: Selecting Media Type

Data/ Step	Ready	Error	RtW	Button	Comment
3	Release the button when LED corresponding to your media type flashes				
3a	1			0	Labels with gaps.
3b		1		0	Ticket with mark.
3c			1	0	Variable length strip.
4	The printer will automatically perform a sensor calibration (Testfeed) according to your selection, and will select thermal transfer printing if ribbons is installed, otherwise direct thermal.				

Testmode: Printing Test Labels

Data/ Step	Ready	Error	RtW	Button	Comment
5	The printer will then print four test labels after the testfeed in step 4. To skip any test labels tap the button.				

Testmode: Running the Dump mode

Step	Data/Ready	Error	RtW	Button	Comment
6					The printer is now in Dumpmode and the printer scans the communication ports. The printer will print any characters it received on the communication ports to a label when exiting dump mode.
7					Tap the button once to exit Dumpmode. If you tap the button within two seconds of entering dump mode, no labels are printed.
8	1		1		The printer will start as on rebooted status. When operational, Data/Ready and RtW will be lit.

Extended Testmode

The extended testmode can be used to run additional tests. This includes the option to print test labels, running a testfeed in slow mode, entering dump mode and resetting to factory defaults. The extended Testmode is entered by raising the printhead, and switching power on while keeping the Print button pressed. Extended Testmode will run a sequence which can be controlled via the Print button, and raising or lowering the printhead. The sequence of steps in the Extended Testmode follows in the table:

Extended Testmode: Activating

Step	Data/Ready	Error	RtW	Button	Comment
1				1	Make sure the printhead is lifted. Press and hold the Print button and switch the printer On. Extended Testmode is activated after 10 seconds.
2	flash	flash	flash		All 3 LEDs flash rapidly four times. Extended Testmode is activated. Release button to continue.

Extended Testmode: Selecting Function

Step	Data/Ready	Error	RtW	Button	Comment
3	flash	flash	flash	0	LEDs flash fast four times, in four-second intervals.
4			flash		Lower the printhead.
5				1	Press the Print button and hold.
6	Release the button when LED combination corresponding to your choice of function flashes. Then see corresponding function table below.				
7a	0	0	1		Testfeed Mode Slow function
7b	0	1	0		Test Label function.
7c	0	1	1		Dump mode function.
7d	1	0	0		Factory default function.
7e	1	1	1		Exit Extended Testmode.

The functions 7a-7e are described on the next page.

Extended Testmode: 7a - Testfeed Mode Slow Function

Step	Data/Ready	Error	RtW	Button	Comment
7a			1		LEDs flash once per second.
				1	Tap the Print button to start Testfeed (Mode slow). Test label is printed.
			1		LEDs flash once per second.
Press Print button and hold it to exit Test Label function and return to Step 6.					

Extended Testmode: 7b - Test Label Function

Data/ Step	Ready	Error	RtW	Button	Comment
7b		1			LEDs flash once per second.
				1	Tap the Print button, once for each of 7 test labels.
Press Print button and hold it to exit Testfeed Mode Slow function, and return to step 6.					

Extended Testmode: 7c - Dumpmode Function

Data/ Step	Ready	Error	RtW	Button	Comment
7c		1	1		LEDs flash once per second.
				1	Tap the Print button to start Dumpmode.
The printer will autohunt the communication ports.					
Tap the button to exit.					
Press >1 second to save dumpmode info.					
		1	1		LEDs flash once per second.
Press button and hold it to exit this function and return to Step 6.					

Extended Testmode: 7d - Factory Default Function

Data/ Step	Ready	Error	RtW	Button	Comment
7d	1				LEDs flash once per second.
Lift the printhead, tap the Print button, and lower the printhead. LEDs will flash.					
Tap the button. Printer will start resetting to factory defaults. This is indicated by scrolling LEDs.					
				1	LED flashes once per second, indicating factory default reset is done.

Extended Testmode: 7d - Factory Default Function

Data/					
Step	Ready	Error	RtW	Button	Comment
Press the button > 1 second to perform testfeed. When done, printer will be ready for use (out of Testfeed mode.)					

Extended Testmode: 7e - Exit

Data/					
Step	Ready	Error	RtW	Button	Comment
7e	1	1	1	1	LEDs flash once per second.
				1	Tap the Print button to exit Extended Testmode.
The LEDs flash rapidly, and printer is ready for use.					

Upgrading Firmware

The www.intermec.com web site contains the latest software that you can download for free.

To download firmware updates

- 1 Visit the Intermec web site at www.intermec.com.
- 2 Click **Service & Support > Downloads**.
- 3 In the **Select a Product** field, choose the EasyCoder PD41 and you will be presented with the latest software available.
- 4 Download the latest firmware version to your computer.
- 5 Extract the zip file to a folder on your computer. Normally, three versions of the firmware are included with the following differences and naming convention:
 - No suffix: Normal firmware upgrade.
 - FD suffix: Firmware upgrade resetting Factory Default. Only applicable when upgrading through a Compact Flash card.
 - NU suffix: Boots with new firmware, yet printer returns to previous firmware version on reboot (No Upgrade). Only applicable when upgrading through a Compact Flash card.

To upgrade the downloaded firmware to your printer, use any one of the following methods:

- Use PrintSet 4 and follow the firmware upgrade procedure.
- If you have a network connection, browse to the printer's home page (see Chapter 2, "Network connection"), and select Maintenance. Upload the firmware file.
- Copy the firmware binary file to a CompactFlash card. Turn the printer off, insert the card into the printer's CompactFlash socket and switch on the printer. The printer will be upgraded automatically.

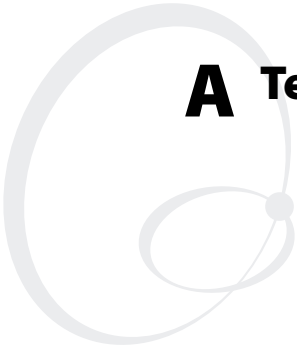

A Technical Data

This Appendix lists technical specifications for the EasyCoder PD41. The appendix contains:

- Table of Printer Specifications

Printer Specifications

Printer Specifications Table

Physical Dimensions		
Dimensions (WxLxH)	276 x 454.4 x 283.0 mm (10.85 x 17.9 x 11.2 inches)	
Weight (excl. media)	13 kg (28.7 pounds)	
Power Supply		
Input Rating	100-240 VAC, 2-1 A, 50/60 Hz	
Power Consumption	<ul style="list-style-type: none"> • Stand-by : 12W • Normal operation/printing: 80W • Peak: 250W 	
Printing		
Print Technique	Direct Thermal/Thermal Transfer	
Printhead Resolutions	8 dots/mm (203.2 dpi) or 11.81 dots/mm (300dpi)	
Print Speed		
8 dots/mm (203 dpi)	50.8 to 152.4 mm/sec . (2 to 6 in./sec.)	
11.8 dots/mm (300dpi)	50.8 to 101.6 mm/sec. (2 to 4 in./sec.)	
Print Width Max.		
8 dots/mm (203 dpi)	104 mm (4.09 in.)	
11.8 dots/mm (300dpi)	105.7 mm (4.16 in.)	
Print Length Max.	Fingerprint	IPL
8 dots/mm (203 dpi)	1270 mm (50 in.)	600 mm (23 in.)
11.8 dots/mm (300dpi)	558.2 mm (22 in.)	406.4 mm (16 in.)
Modes of Operation		
Tear-Off (Straight-through)	Yes	
Cut-off	Option with cutter	
Peel-Off (self-strip)	Option with internal rewinder	
Firmware (Fingerprint)		
Operating System	Fingerprint v10.0.X	Includes Direct Protocol
Smooth Fonts	TrueType and TrueDoc fonts	

Printer Specifications Table

Resident scaleable fonts	15
Character Sets	<ul style="list-style-type: none"> • 23 single-byte character sets standard. • UTF-8 support as standard.
Resident Bar Codes	61
Firmware (IPL)	
Operating System	IPL v10.0.X
Smooth Fonts	TrueType and TrueDoc fonts
Resident scaleable fonts	13 (+21 simulated bitmap)
Character sets	<ul style="list-style-type: none"> • 23 single-byte character sets standard. • UTF-8 support as standard.
Resident Bar Codes	31
Environment	
Operating temperature	+5°C to +40°C (+41°F to 104°F)
Storage temperature	-20°C to 70°C (-4°F to 122°F)
Operating Humidity	20 to 80% non-condensing
Storage Humidity	10 to 90% non-condensing
Media	
Media width	25 to 118 mm (1 to 4.65 inches) Max 114mm (4.49 in.) with cutter.
Media Roll diameter	213 mm (8.35 in.) max. 190 mm (7.5 in.) with internal rewinder.
Internal Rewinder diameter	Max 140 mm (5.51 in.)
Media Roll Core Diameter	38.1 to 76.2 mm (1.5 to 3 in.)
Media Thickness	60 µm to 250 µm (2.3 to 9.8 mils)
Transfer Ribbon	
Material	Wax, hybrid, or resin
Winding	Ink on either inside or outside of roll
Ribbon width	30 to 110 mm (1.18 to 4.33 in.)
Ribbon Roll Diameter (outer)	76 mm (2.99 in.) equivalent to 450 meters (1471 ft) of ribbon.
Inner core Diameter	25.2 to 25.6 mm (1 in.)

Printer Specifications Table

Sensors	
Label Gap/Black Mark/ Out of Media	Yes
Printhead Lifted	Yes
Label Taken	Yes
Ribbon End	Yes
Controls	
LED indicators	4: Power, Data/Ready, Error, Ready-to-Work
Keys	One
Electronics	
Micropocessor	ARM 9
Standard Memory	4 MB Flash, 8 MB SDRAM.
Interfaces	
RS-232 Serial	Yes
USB	Yes
Ethernet	Yes/Option
IEEE 1284 Parallel	Yes/Option
CompactFlash	Yes
Accessories and Options	
Internal Rewinder and Batch Takeup	
Cutter	
Printhead 203/300 dpi	
EasyLAN Ethernet Interface	
Parallel IEEE 1284 Interface	

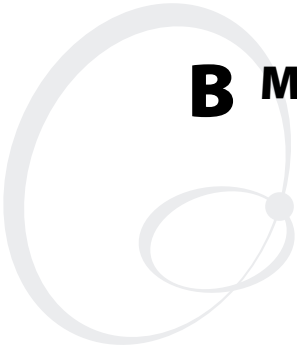

B Media Specifications

This appendix illustrates the different media types the EasyCoder PD41 can operate with, and states the allowed dimensions of the paper, ribbon and rolls. This appendix covers the following topics:

- Media Roll Sizes
- Paper Types and Sizes

Media Roll Sizes

The media roll must comply with the following dimensions:

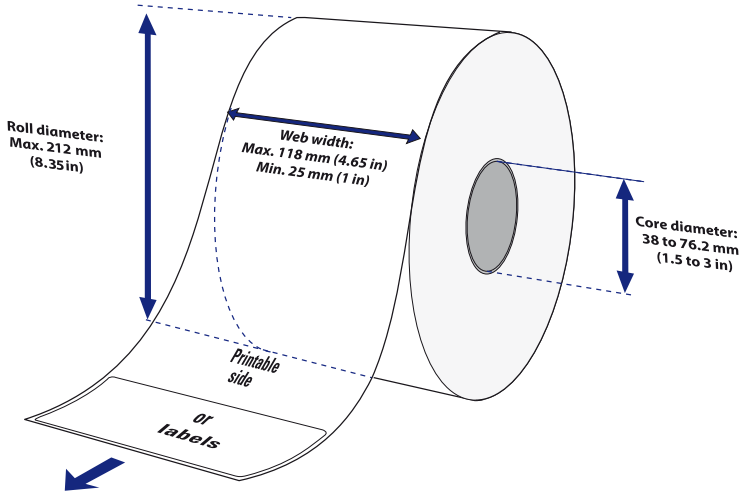

Media roll dimensions

Core

- Diameters: 38 to 76.2 mm (1.5 to 3 inches)
- Width: Must not protrude outside the media.

Internal Roll

Max. diameter	212 mm	8.35 inches
Max diameter with internal rewriter	190 mm	7.5 inches
Max. width	118 mm	4.65 inches
Max. width with cutter	114 mm	4.49 inches
Min. width	25 mm	1.00 inches
Thickness	60 to 250 μ m	2.3 to 9.8 mils

Thicker media may be used, but print quality will be reduced. the stiffness is also important, and must be balanced against thickness to maintain print quality.

The media supply must not be exposed to sand, dust, grit etc. Any hard particles, no matter how small, can damage the printhead.

Ribbon Size

The core of the ribbon must be 25.2-25.6 mm (1 inch), as the empty ribbon core included in the box. The outer dimensions of the ribbon roll may be:

Max. diameter	76 mm	2.99 inches
Max. width	110 mm	4.33 inches
Min. width	30 mm	1.18 inches

Paper Types and Sizes

Non-Adhesive Strip

a: Media Width

Maximum:	118.0 mm	4.65 inches
Minimum:	25.0 mm	1.00 inches

Paper Type Setup

- Variable length strip
- Fixed length strip



Non-adhesive strip

Self-Adhesive Strip

a: Media Width

Maximum:	118.0 mm	4.65 inches
Minimum:	25.0 mm	1.00 inches

b: Liner

The liner must extend evenly on both sides and not more than a total of 1.6 mm (0.06) inches outside the face material.

c: Media Width (excluding liner)

Maximum:	116.4 mm	4.58 inches
Minimum:	23.8 mm	0.94 inches

Paper Type Setup

- Variable length strip
- Fixed length strip



Self-adhesive strip

Self-Adhesive Labels

a: Media Width

Maximum:	118.0 mm	4.65 inches
Minimum:	25.0 mm	1.00 inches

b: Liner

The liner must extend evenly on both sides and not more than a total of 1.6 mm (0.06) inches outside the face material.

c: Label Width (excluding liner)

Maximum:	116.4 mm	4.58 inches
Minimum:	23.8 mm	0.94 inches

d: Label Length

	Fingerprint	IPL
8 dots/mm (203 dpi)		
Maximum:	1270 mm (50 in.)*	600 mm (23 in.)
Minimum:	6 mm (0.2 in.)	6 mm (0.2 in.)
11.81 dots/mm (300 dpi)		
Maximum:	558.8 mm (22 in.)*	406.4 mm (16 in.)
Minimum:	6 mm (0.2 in.)	6 mm (0.2 in.)

* This is the print length limit set by memory constraints.

e: Label Gap

Maximum:	26.0 mm	1.02 inches
Minimum:	1.2 mm	0.05 inches
Recommended:	3.0 mm	0.12 inches

The Label Gap sensor must be able to detect the front edges of the labels. It can be moved 0 to 57 mm (0 to 2.24 inches) from the inner edge of the media.

Paper Type Setup

- Labels with Gaps

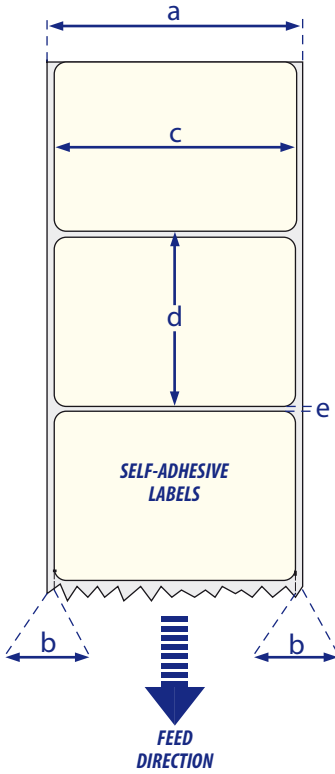

Self-adhesive Labels

Tickets with Gaps

a: Media Width

Maximum:	118.0 mm	4.65 inches
Minimum:	25.0 mm	1.00 inches

b: Copy Length

Fingerprint

IPL

8 dots/mm (203 dpi)

Maximum:	1270 mm (50 in.)*	600 mm (23 in.)
Minimum:	6 mm (0.2 in.)	6 mm (0.2 in.)

11.81 dots/mm (300 dpi)

Maximum:	558.8 mm (22 in.)*	406.4 mm (16 in.)
Minimum:	6 mm (0.2 in.)	6 mm (0.2 in.)

* This is the print length limit set by memory constraints.

c: Detection Position

Variable: 0 to 57 mm 0 to 2.24 inches

d: Detection Slit Length

The length of the detection slit (excluding corner radius) must be minimum 2.5 mm (0.10 inches) on either side of the detection position.

e: Detection Slit Height

Maximum:	26.0 mm	1.02 inches
Minimum:	1.2 mm	0.05 inches
Recommended:	3.0 mm	0.12 inches

Paper Type Setup

- Tickets with Gaps



Note: Do not allow any perforation to break the edge of the media as this may cause the media to split and jam the printer.

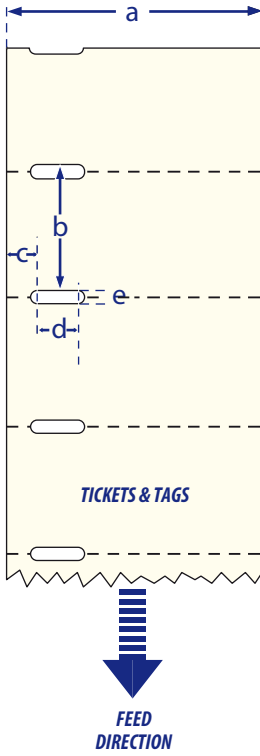

Tickets with Gaps

Tickets with Black Mark

a: Media Width

Maximum:	118.0 mm	4.65 inches
Minimum:	25.0 mm	1.00 inches

b: Copy Length

Fingerprint

IPL

8 dots/mm (203 dpi)

Maximum:	1270 mm (50 in.)*	600 mm (23 in.)
Minimum:	6 mm (0.2 in.)	6 mm (0.2 in.)

11.81 dots/mm (300 dpi)

Maximum:	558.8 mm (22 in.)*	406.4 mm (16 in.)
Minimum:	6 mm (0.2 in.)	6 mm (0.2 in.)

* This is the print length limit set by memory constraints.

c: Detection Position

Variable: 0 to 57 mm 0 to 2.24 inches

d: Black Mark Width

The detectable width of the black mark should be at least 5.0 mm (0.2 inches) on either side of the Label Gap Sensor detection point.

e: Black Mark Length

Maximum:	25.0 mm	0.98 inches
Minimum:	3 mm	0.12 inches
Common:	5 mm	0.2 inches

f: Black Mark Y-Position

It is recommended that you place the black mark as close to the front edge of ticket as possible and use a negative Stop Adjust value to control the media feed, so the tickets can be properly torn off.

Paper Type Setup

- Tickets with Mark



Note: Preprint that may interfere with the detection of the black mark should be avoided.



Note: the black mark should be non-reflective carbon black on a white or near-white background. Do not allow any perforations to break the edge of the media as this may cause the media to split and jam the printer.

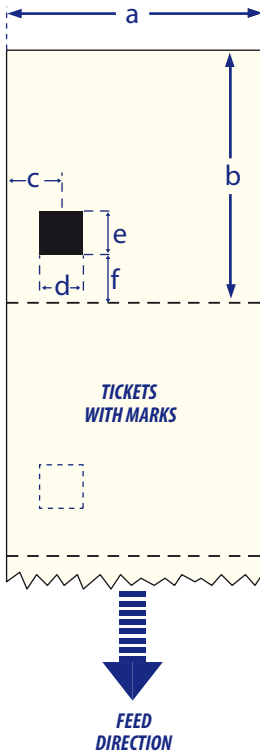

Tickets with Black Mark



C Setup Parameters (Fingerprint)

This appendix lists all of the setup parameters that you can configure to fit your operating environment. This appendix covers the following topics:

- Setup Description
- Serial Communication Setup
- Feed Adjust Setup
- Media Setup
- Print Definitions Setup

Setup Description

The printer's Setup parameters are used to set the printer's operational behavior. Chapter 5, "Configuring Settings", explains how to set or change the parameters, and this is also explained in the *Fingerprint v10.X.X Programmer's Reference Manual*, under the `SETUP` command.



Note: The recommended way to set your printer's configuration parameters is to use the PrintSet 4 program, which is included on the PrinterCompanion CD. PrintSet 4 can communicate with your printer either via a serial cable or a network connection.

Serial Communication Setup

The serial communication parameters control the communication between the printer and the connected computer or other devices on the standard serial port, referred to as "uart1:".

For the serial communication channel ("uart1:"), the following parameters can be set. Make sure they match the setup of the connected device or vice versa. If the setup of the printer and the setup of the host do not match, the response from the printer to host will be garbled.

Baud Rate

The baud rate is the transmission speed in bits per second. There are 10 options:

- 300
- 600
- 1200
- 2400
- 4800
- 9600 (default)
- 19200
- 38400
- 57600

- 115200

Character Length

The character length specifies the number of bits that will define a character. Eight bits are recommended, since that option allows more special characters and characters that are used exclusively in foreign languages. Refer to the *Intermec Fingerprint v10.X.X, Programmer's Reference Manual* for more information.

- 7 (Characters ASCII 000 to 127 decimal)
- 8 (Characters ASCII 000 to 255 decimal). Default.

Parity

The parity decides how the firmware will check for transmission errors. There are five options:

- None (default)
- Even
- Odd
- Mark
- Space

Stop Bits

The number of stop bits specifies how many bits will define the end of a character. There are two options:

- 1 (default)
- 2

Flow Control

RTS/CTS is a protocol in which communication is controlled via currents through separate lines in a cable that are set either to HIGH or LOW. By default, this option is disabled.

CTS on the Printer is connected to RTS on the PC and vice versa. CTS HIGH from the printer indicates that the unit is ready to receive data.

CTS LOW from the printer indicated that the receive buffer is full (see XON/XOFF). In some computer programs, e.g. Microsoft Windows HyperTerminal, RTS/CTS is designated "Hardware."

XON/XOFF is a protocol in which communication is controlled by the control characters XON (ASCII 17 dec.) and XOFF (ASCII 19 dec.) transmitted on the same line as the data. XON/XOFF can be enabled/disabled separately for data received from the host by the printer (printer sends XON/XOFF) and for data transmitted to the host from the printer (host sends XON/XOFF).

New Line

Selects the character or characters transmitted from the printer to indicate a new line. There are three options:

- CR/LF ASCII 13 + 10 dec. (default)
- LF ASCII 10 dec.
- CR ASCII 13 dec.

Receive Buffer

The Receive buffer stores the input data before processing. The size is 8192 bytes and cannot be changed.

Transmit Buffer

The transmit buffer stores the input data before processing. Default size is 8192 bytes and cannot be changed.

Feed Adjust Setup

The Feedadjust part of the Setup Mode controls how much of the media is fed out or pulled back before and/or after the actual printing. These settings are global and will be effected regardless of which program is run.



Note: The firmware uses the front edges of labels with gaps, the ends of detection slots, and the forward edges of black marks for detection, all seen in relation to the feed direction.

Start Adjust

The Start Adjust value is given as a positive or negative number of dots. Default value is 0, which places the origin a certain distance back from the forward edge of the copy.

- A positive start adjustment means that the specified length of media will be fed out before the printing starts. Thus, the

origin is moved further back from the forward edge of the copy.

- A negative start adjustment means that the specified length of media will be pulled back before the printing starts. Thus, the origin is moved towards the forward edge of the copy.

Stop Adjust

The Stop Adjust value is given as a positive or negative number of dots. Default value is 0, which stops the media feed in a position suitable for tear off operation.

- A positive stop adjustment means that the normal media feed after the printing is completed will be increased by the specified value.
- A negative stop adjustment means that the normal media feed after the printing is completed will be decreased by the specified value.

Media Setup

The media parameters tell the firmware the characteristics of the media that will be used, so that the printout will be positioned correctly and attain the highest possible quality.

Media Size

The size of the printable area is defined by three parameters; X-Start, Width, and Length.

X-Start

Specifies the position of the origin along the dots on the printhead.

The default X-start value prevents printing outside the labels when the liner is slightly wider than the labels. If you want to maximize the print width, reset the X-start value to its default: 0.

By increasing the value for the X-start parameter, the origin will be moved outwards, away from the inner edge of the media path. In other words, the larger X-start value, the wider inner margin and the less available print width.

Width

Specifies the width of the printable area in number of dots from the origin. Thus, the sum of the X-start and width values gives the outer margin of the printable area. The width should be set to prevent printing outside the media, which may harm the printhead.

Length

Specifies the length of the printable area in number of dots from the origin along the Y-coordinate and allocates memory space for two identical image buffers in the printer's temporary memory.

The size of each buffer can be calculated using this formula:

Buffer size (bits) = [Print length in dots] x [Printhead width in dots]

- The length setup also decides the amount of media feed when using “fix length strip.”
- The length setup creates an emergency stop, which works when the printer is set up for “Label (w gaps)”, “Ticket (w mark)”, or “Ticket (w gaps).” If the label stop sensor has not detected a gap or mark within 150% of the set length, the media feed is automatically stopped to avoid feeding out a whole roll of media, due to sensor malfunction.

By setting up the X-start, the Width, and the Length, you will create a print window inside which printing can be performed. Any object or field extending outside the print window in any direction will either be clipped or cause an error condition (Error 1003 “Field out of label”), see *Intermec Fingerprint v10.xx, Programmer's Reference Manual*.

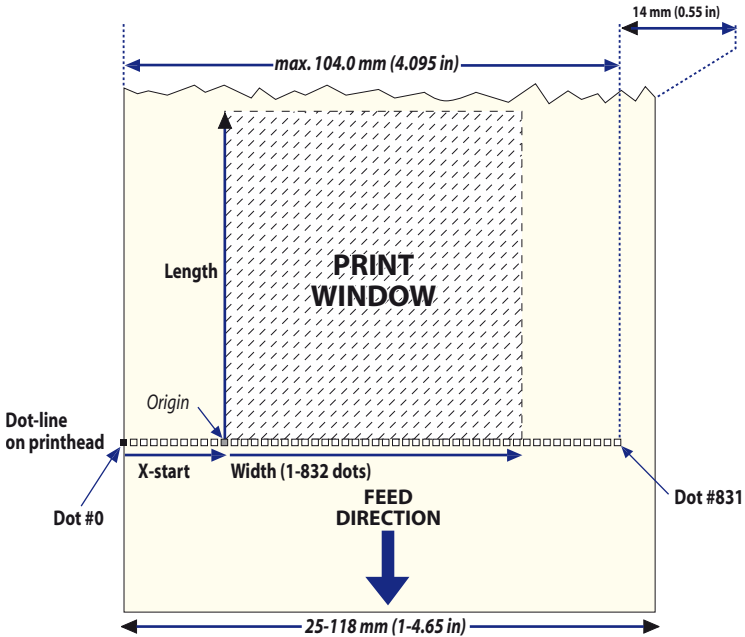

Print Window: 8 dots/mm standard printhead

Media Type

The Media Type parameter controls how the label stop sensor (LSS) and the media feed work. There are five media type options, see also Appendix B, “Media Specifications”:

- Label (w gaps) is used for adhesive labels mounted on liner.
- Ticket (w mark) is used for labels, tickets, or continuous stock provided with black marks at the back.
- Ticket (w gaps) is used for tickets and tags with detection slits.
- Fix length strip is used for continuous stock where the length of the print window decides the length of media to be fed out.
- Var length strip is used for continuous stock. The size of the print images decides the length of each copy.

It is important to select the correct media type, so the printer can communicate the following errors.

- Error 1005 “Out of paper” indicates that the last ordered copy could not be printed because of an empty media stock.

Appendix C — Setup Parameters (Fingerprint)

- Error 1031 “Next label not found” indicates that the last ordered label or ticket was successfully printed, but no more labels/tickets can be printed because of an empty media stock.

Paper Type

The Paper Type parameters control the heat emitted from the printhead to the direct thermal media or, optionally, the transfer ribbon in order to produce the dots that make up the printout image.

Labels, tickets, tags, strip, and ribbons for various types of application are available from Intermec. To attain optimal printout quality and extending the life of the printhead, use Intermec supplies. Heat setting recommendations for Intermec media can be found from the Intermec website:

www.intermec.com/eprise/main/Intermec/Content/Products/Products_HeatSettings

As a general rule, high energy and/or high print speed will shorten the life of the printhead. Never use incorrect paper type settings or higher print speed settings than necessary for obtaining an acceptable printout quality and throughput speed.

If the ambient temperature is lower than +15°C (+59°F), decrease the print speed by 50 mm/sec.

Start by choosing between two alternatives:

- Direct Thermal printing (option)
- Thermal Transfer printing (default)



Note: It is highly recommended to use PrintSet 4 to set the Paper Type setup parameters. PrintSet 4 includes a Print Quality Wizard that guides you through the process of improving printout quality.

Your choice will decide which parameters to enter next:

Direct Thermal Printing

- Label Constant (range 50 to 115). Default 85.
- Label Factor (range 10 to 50). Default 40.

The following table gives initial recommendations for suitable settings.

Direct Thermal Recommended Settings

Paper sensitivity	Label Constant	Label Factor	Max Print Speed (203 dpi)	Max Print Speed (300 dpi)
Low	100	40	75	50
Standard	90	40	100	75
High	80	40	125	100
Ultra High	70	40	150	100

Use the above settings as initial settings and adjust the Label Constant if necessary.

Thermal Transfer printing

- Ribbon Constant (range 50 to 115). Default 90.
- Ribbon Factor (range 10 to 50). Default 25.
- Label Offset (range -50 to 50). Default 0.

The following tables gives initial recommendations for suitable settings.

Thermal Transfer Recommended Settings

Ribbon	Ribbon Constant	Ribbon Factor	Max Print Speed (203 dpi)	Max Print Speed (300 dpi)
Wax	80	20	75	75
Hybrid (Wax/Resin)	90	25	100-150	75-100
Resin	100	30	150	100

The receiving material has been excluded from this table, since the ribbon has the largest impact for heat settings for thermal transfer settings.

Use the above settings as initial values, and adjust the Ribbon Constant if necessary.

Contrast

Use the contrast parameter to make minor adjustments of the blackness of the printout, for example to adapt the printer to variations in quality between different batches of the same media. The options are values between -10% to 10% in steps of 2. Default value is 0%. The contrast is reset to the default value whenever a new paper type is specified, regardless which method has been used.

Testfeed

The Testfeed is a read-only parameter that indicates internal parameters for the Label Stop Sensor. These are automatically set when running a Testfeed (by pressing Print button more than one second.) It is very important to run a testfeed when switching from one media type to another.

Testfeed Mode

In certain unusual cases, a Testfeed may have been unable to successfully identify gaps or marks in the media. It is thus possible to set the Testfeed Mode to Slow to allow the Label Stop Sensor to more easily identify media gaps/marks. The options are Slow and Fast (default).

LEN (Slow Mode)

When the Testfeed Mode is set to slow, the printer will sample the media length plus 10mm. You can change the sample length by specifying the number of dots in LEN(Slow Mode), the minimum being the number of dots corresponding to 10mm. The default (media length plus 10mm) is specified by the value 0.

Print Definitions

Print Speed

The Print Speed is specified in mm/second. Allowed values are 50-150 mm/s (2-6 ips) for the 203dpi printhead and 50-100 mm/s (2-4 ips) for the 300 dpi printhead. Default is 100 mm/s (4 ips) and 75 mm/s (3 ips) for 203 and 300 dpi printheads respectively.



D Setup Parameters (IPL)

This appendix lists all of the setup parameters that you can configure to fit your operating environment. This appendix covers the following topics:

- Setup Description
- Serial Communication Setup
- Media Setup
- Configuration Setup
- Returning to Factory Default Setup

Setup Description

The printer's Setup parameters are used to set the printer's operational behavior. "Changing Configuration Settings" on page 44, explains how to view or change the parameters, and this is also explained in the *IPL Programmer's Reference Manual*.



Note: The recommended way to set your printer's configuration parameters is to use the PrintSet 4 program, which is included on the PrinterCompanion CD. PrintSet 4 can communicate with your printer either via a serial cable or a network connection.

About Test labels

Test labels that give detailed information about the printer's software, hardware and network settings can be printed in testmode or extended testmode, but also by sending commands through the terminal window. For example, the following commands print a software configuration label, and then resets the printer in programming mode:

```
<STX><ESC>T; s<ETX>  
<STX><ESC>P<ETX>
```

Please refer to the *IPL Programmer's Reference Manual* for more information on how to print test labels.

Serial Communication Setup

The serial communication parameters control the communication between the printer and the connected computer or other devices on the standard serial port.

Make sure the printer's communication parameters match the setup of the connected device or vice versa. If the setup of the printer and the setup of the host do not match, the response from the printer to host will be garbled.

Baud Rate

The baud rate is the transmission speed in bits per second. There are 10 options:

- 1200
- 2400

- 4800
- 9600 (default)
- 19200
- 38400
- 57600
- 115200

Character Length

The character length specifies the number of bits that will define a character. Eight bits are recommended, since that option allows more special characters and characters that are used exclusively in foreign languages. Refer to the *IPL Programmer's Reference Manual* for more information.

- 7 (Characters ASCII 000 to 127 decimal)
- 8 (Characters ASCII 000 to 255 decimal). Default.

Parity

The parity decides how the firmware will check for transmission errors. There are five options:

- None (default)
- Even
- Odd
- Space

Stop Bits

The number of stop bits specifies how many bits will define the end of a character. There are two options:

- 1 (default)
- 2

Protocol

XON/XOFF (default)

In the XON/XOFF protocol, data flow control is achieved by using XON (DC1) and XOFF (DC3) characters. Message blocks are not required to be bracketed by the Start of Text (STX) and End of Text (ETX) characters. However, at power up or after a reset all characters except ENQ or VT will be ignored until an STX is detected. The message length in this protocol is unrestricted. That is, the printer processes information as it is being downloaded and stops when there is no more information.

XON/XOFF protocol conforms to generally accepted industry standards. No end-of-message response is sent to the host other than XOFF. An XON will be sent on power up.

Since DC1 and DC3 are used for data flow control, the printer status characters are different than those of the Standard Protocol. If the host ignores the printer's XOFF, the printer will resend an XOFF after receiving every 15 characters from the host.

Condition	Character
Buffer already full	GS
Printhead raised	US
Ribbon fault	US
No label stock	EM
Buffer now full	DC4
Printhead hot	SI
Label at strip pin	FS
Label skipping	DC2
Printing	DC2

Intermec Standard Protocol

The Intermec Printer Standard Protocol is a half-duplex protocol. All data transmissions to the printer consist of status inquiry (ENQ), status dump (VT), or message blocks. Each message block starts with the Start of Text (STX) character and ends with the End of Text (ETX) character. Each message block must be 255 characters or less, including the STX and ETX

characters. The printer responds to each status inquiry or message block with the printer status. The host should check the printer status before downloading a message block to the printer. ENQ causes the printer to transmit its highest priority status, while VT instructs the printer to transmit all status that applies in the order of their priority. The possible printer status in descending priorities are

Condition	Character
Buffer already full	GS
Printhead raised	US
Ribbon fault	US
No label stock	EM
Buffer now full	DC3
Printhead hot	SI
Label at strip pin	FS
Label skipping	DC1
Ready	DC1
Printing	DC1

Media Setup

The media parameters tell the firmware the characteristics of the media that will be used, so the printout will be positioned correctly with optimal quality.

Media Type

The Media Type parameters control how the label stop sensor (LSS) and the media feed work. There are three media type options:

- Gap is used for adhesive labels mounted on liner (backing paper) or continuous paper stock with detection slots. Default.
- Mark is used for labels, tickets, or strip provided with black marks at the back.
- Continuous is used for continuous stock without any detection slots or black marks.

Paper Type

The Paper Type parameters control how the transfer ribbon mechanism and the ribbon sensor work. There are two paper type options:

- DT (Direct Thermal) is used for heat-sensitive media without any need for a thermal transfer ribbon. Default.
- TTR (Thermal Transfer) is used for non heat-sensitive receiving face materials in combination with a thermal transfer ribbon.

Label Length Dots

The Label Length setup specifies the length in dots of each copy along the media feed direction (X-coordinate). This is used for “label-out” detection.

Sensitivity (Media Sensitivity Number)

This setup parameter specifies the characteristics of the direct thermal media or combination of receiving face material and thermal transfer ribbon, so the printer’s firmware can optimize the heating of the printhead and the print speed. Standard supplies from Intermec are labeled with a 3-digit media sensitivity number which is used to specify the media grade. Look for the media sensitivity number on:

- The side of the media roll. Use the last three digits of the 15-digit number stamped on the roll for the media sensitivity number.
- A small label attached to the roll of media.
- A small label attached to the plastic bag of your ribbon roll.

The sensitivity number on each roll of thermal transfer media or ribbon has an asterisk (*) in place of one of the digits. To optimize the sensitivity number for thermal transfer media, you combine the digits as in this example.

Media or Ribbon	Sensitivity Rating	Description
Thermal transfer media	56*	The asterisk for the third digit is reserved to identify the ribbon's sensitivity number.
Thermal transfer ribbon	5*7	The asterisk for the second digit is reserved to identify the media's sensitivity number.
	=567	Optimum sensitivity rating

The media sensitivity number can also be changed using PrintSet, the printer's home page, third-party software, or an IPL command with the following syntax:

```
<SI>gn [, m]
```

where:

n specifies direct thermal(*n*=0) or thermal transfer(*n*=1) media.

m specifies the sensitivity.

The default sensitivity number is 420 for direct thermal printing and 567 for thermal transfer printing.



Note: A list of Sensitivity numbers for different ribbon and media types can be found on the Intermec website. Go to www.intermec.com. Choose **Products** > **Printers**, and click **Heat settings**.

Darkness

Use this parameter to make minor adjustments of the blackness in the printout, for example to adapt the printer to variations in quality between different batches of the same media type. The value can be set within the range -10% to +10% where -10 is the lightest and 10 is the darkest. Default value is 0%.

Label Rest Point

Specifies where labels stop for removal. Use this for peel-off (self-strip) applications. Allowed range is -30 (furthest back) to 30 (furthest forward). Default is 0. Also available as an IPL command (<SI>fn).

Form Adj Dots X

Specifies where the X-position of the origin should be placed on the label. Allowed range is -30 (closest to the leading edge) to 30 (furthest from the leading edge). Default is 0.

Form Adj Dots Y

Specifies where the Y-position of the origin should be placed on the label. Allowed range is -30 (closest to the center section) to 30 (furthest from the center section). Default is 0.

Configuration Setup

Emulation

Emulation mode lets you print bar code labels that were originally designed on an 86XX printer in multiples of 10 or 15 mil. When the printer is working in emulation mode, not all IPL commands are supported. For a complete list of commands available during emulation mode, see the the *IPL Programmer's Reference Manual*.

Default emulation mode is “none”.

Print Speed

You can select the print speed from 2 in./sec. (50 mm/sec.) to 6 in./sec.(100 mm/sec.) with an interval of 1 in./sec. The higher the print speed, the more wear on the printhead, so do not use a higher print speed than necessary. For some direct thermal media or ribbon/media combinations, setting the highest print speed may reduce print quality significantly.

Cutter (option)

Once a cutter has been installed in the printer, it must also be enabled in the firmware. IPL commands are used to enable/disable the cutter in configuration mode:

<code><STX>R<ETX></code>	Enter print/configuration mode
<code><STX>SIc1<ETX></code>	Enable cutter
<code><STX>SIc0<ETX></code>	Disable cutter

Label Taken Sensor

To make the printer work in Peel off (self-strip) mode, that is, waiting for a label to be removed before the next label is printed, the self-strip mode must be enabled. This can be done by executing the following commands:

<STX>R<ETX> Enter print/configuration mode
<STX><SI>t0<ETX> Disable self-strip
<STX><SI>t1<ETX> Enable self-strip

Returning to Factory Default Setup

You can restore all the printer's default settings in extended testmode (see page 47), or by using the Factory Default Wizard in PrintSet 4.

Appendix D — Setup Parameters (IPL)



E Interfaces

This appendix describes the default interfaces, as well as the optional kits that add functionality to your EasyCoder PD41. This appendix covers the following topics:

- RS-232 Serial Interface
- USB Interface
- EasyLAN Ethernet Interface (Option)
- Parallel IEEE 1284 Interface (Option)

RS-232 Serial Interface

Protocol

Default Setup

Baud rate	9600
Character length	8 bits
Parity	None
Stop bits	1
Handshaking	XON/XOFF and RTS/CTS

To change the Serial settings, see Chapter 5, “Configuring Setup”.

Interface cable

The computer end of the cable depends on the computer model. The printer end is a DB-9pin plug, as shown below.

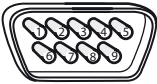

RS-232 DB9-pins

Signals on the printer’s serial port:

DB-9	Signal	Meaning
1		External +5V DC Max 500mA
2	TXD	Transmit data
3	RXD	Receive data
4		
5	GND	Ground
6		
7	CTS	Clear to send
8	RTS	Request to send
9		

USB Interface

The printer supports USB v1.1 (also called USB 2.0 full speed). To use the USB interface to print from a PC, you need to have the Intermec USB printer driver installed on your PC. You will find this driver (InterDriver) on the Printer Companion CD along with installation instructions.

The printer is a so called “self-powered device”. We recommend that you only connect one printer to each USB port on the host, either directly or via a hub. Other devices, like a keyboard and a mouse, can be connected to the same hub. If you need more than one Intermec USB printer to a host, you should use different USB ports.

The USB cable included with the EasyCoder PD41 has a USB Type A connector on one end to connect to a PC, and a USB TypeB connector to connect to the printer.

There is no communication setup for the USB port.

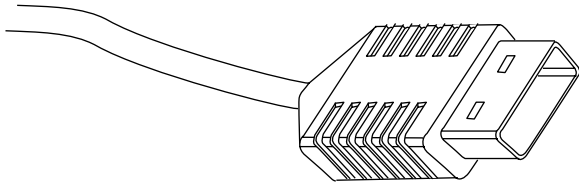

USB Type A connector (connects to PC or hub)

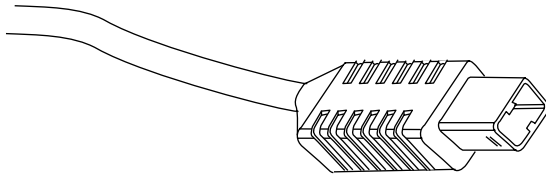

USB Type B connector (connects to printer)

EasyLAN Ethernet Interface

The EasyLAN Ethernet interface has an RJ-45 socket for use with a standard RJ-45 cable. The interface supports 10/100 Mbps Fast Ethernet (10BASE-T, 100BASE-TX) and is fully compliant to the IEEE 802.3u standard. The network card MAC address can be found on the label below the socket.

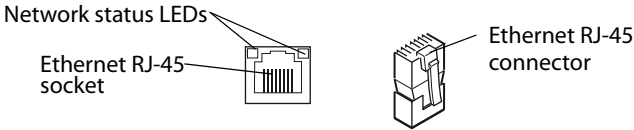

One yellow and one green LED indicate the network status.

Network Status LEDs	
Green On:	Link
Green Off:	No link
Green Blinking:	Activity
Yellow Off:	10BT
Yellow On:	100BT

Parallel IEEE 1284 Interface

The parallel port supports Windows plug-n-play and additional status reporting through IEEE 1284 nibble ID mode.

Interface cable

Parallel cable compatible with PC.

Pinout Description

Pin	Function	Transmitter	Comment
1	nStrobe	host	
2-9	Data 0-7	host	
10	nAcknowledge	printer	
11	Busy	printer	
12	Perror	printer	
13	Select	printer	

Pinout Description

Pin	Function	Transmitter	Comment
14	nAutoFd		
15-16	Not connected		
17	Chassis ground		
18	External +5V DC		Max 500mA
19-30	Signal ground		
31	nInit		
32	nFault	printer	
33	Signal ground		
34-35	Not connected		
36	nSelectIn		



F Options

This appendix describes the options that add functionality to your EasyCoder PD41 Printer. For a complete description and installations instructions, see the respective installation instructions document for each kit. Please note that several of these options can only be factory-fitted or installed by an authorized service technician. This appendix covers the following topics:

- EasyLAN Ethernet
- Parallel IEEE 1284 Interface
- Cutter
- Internal Rewinder and Batch Takeup
- Printhead Kit (203 or 300 dpi)

EasyLAN Ethernet Interface

The EasyLAN Ethernet Interface kit adds network capability to your printer. See “Interfaces” in Appendix E.

Parallel IEEE 1284 Interface

This kit adds a parallel (“centronics”) port to your printer. See the “Interfaces” in Appendix E.

Cutter Kit

The Cutter is designed to cut off continuous paper-based stock or liner between labels. The paper cutter can be controlled using the instructions CUT, CUT ON and CUT OFF in Fingerprint (and Direct Protocol).

Internal Rewinder

The Internal Rewinder (and Batch Takeup) kit is an optional device for peel-off (self-strip) operation, which means that the labels are separated from the liner (backing paper) after printing and the liner is wound up on an internal hub. It can also be used to roll up complete batches of label rolls. The unit also includes a guide shaft. See Chapter 2, “Loading Media”, for instructions on how to load the media for peel-off operation.

Printhead Kit

The printer can be fitted with either a 203dpi or 300dpi printhead. These printheads use different PCBs (printed circuit board?). The printhead kit is thus available as a replacement kit (printhead only), or as a complete kit (printhead plus PCB).



Corporate Headquarters

6001 36th Avenue West
Everett, Washington 98203
U.S.A.

tel 425.348.2600

fax 425.355.9551

www.intermec.com

EasyCoder PD41 Printer User's Guide



P/N 1-960652-01